

# Monteringsvejledning

DK

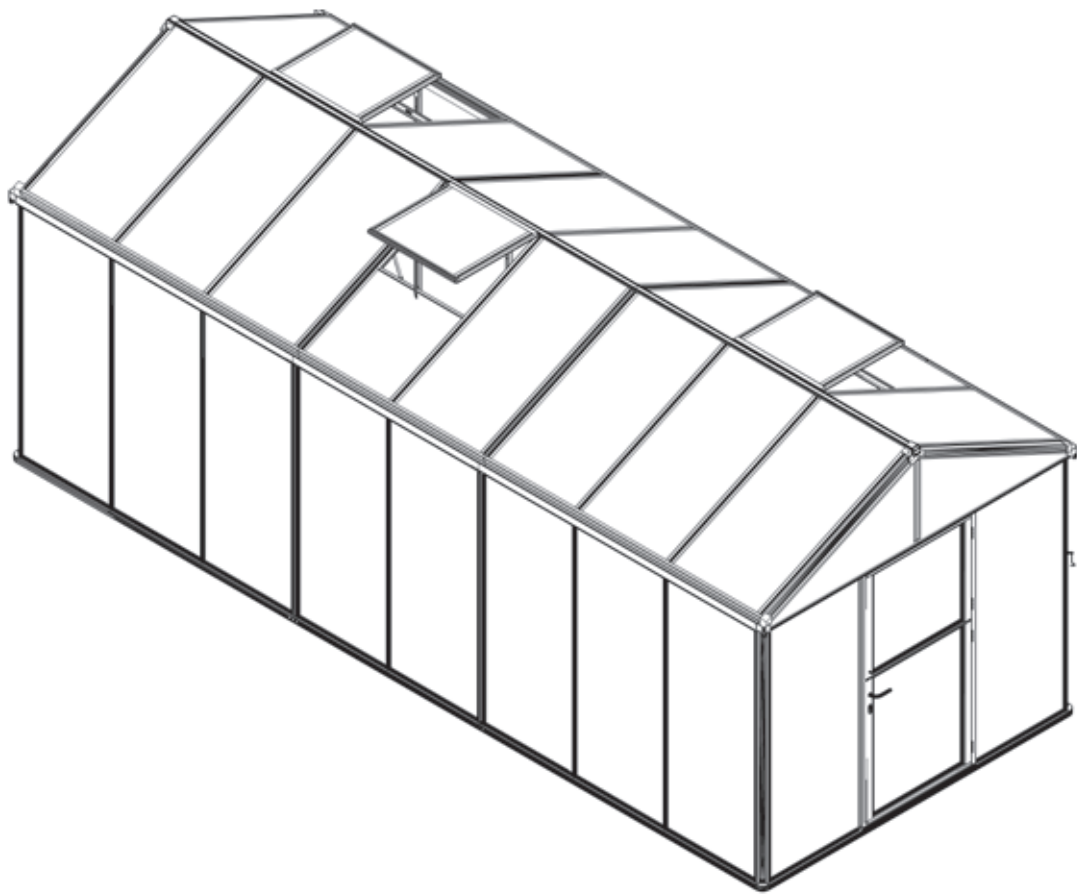

**Vitavia**  
- makes living grow

---

**ZEUS**  
**13500, 15300**

**Kære kunde,**

Tak fordi De har valgt et Vitavia produkt. Vi er overbeviste om, at De vil få megen glæde af og mange gode stunder i Deres drivhus.



**Læs venligst hele denne monteringsvejledning, inden samling og opstilling af drivhuset påbegyndes.**

	Side
• Indhold / symboler	2
• Anbefalinger / gode råd	3
• Sikkerhedshenvisninger	4
• Vedligeholdelse og pleje	5
• Stykliste pakke 1-1	7- 8
• Stykliste pakke 1-2	9-15
• Stykliste pakke 2	16-19
• Stykliste pakke 3	20-23
• Stykliste pakke 4	24-25
• Stykliste pakke 5	26-27
• Fundament / sokkel	28-29
<b>Samling og montering</b>	
• Trin 1 Bundramme og hjørnestolper	30-31
• Trin 2 Midterprofil og tagrem	32-33
• Trin 4 Mellemprofiler	34-35
• Trin 4 Tag	36-39
• Trin 5 Ventilationsvinduer	40-41
• Trin 6 Dør	42-45
• Trin 7 Isætning af glas / polycarbonatplader	46-53
• Trin 8 Færdiggørelse	54-55



Tegninger med enkeltramme er set indefra



Tegninger med dobbeltramme er set udefra



**NB!: Vigtigt tip!  
Bemærk venligst!**



**De bør altid bruge handsker, når De arbejder med polycarbonatplader eller glas. Skarpe kanter kan forårsage skader. Der kan også forekomme skarpe kanter på kanter og hjørner på aluminiumsprofiler. Her bør De også bære handsker. Ved isætning af glas bør De også anvende beskyttelsesbriller, sikkerhedssko og hovedbeskyttelse (sikkerhedshjelm). Itugået glas udgør en sikkerhedsrisiko og bør bortskaffes med forsigtighed.**

### **Bemærk venligst!**

De har købt et drivhus, der er konstrueret til planteavl og udelukkende bør benyttes til dette formål. Ved anden brug bortfalder ethvert producentansvar og garantiforpligtelse/reklamationsret.

Til montage af dette produkt kræves min. 2 personer.

Skulle De få problemer med drivhusmontagen eller glasisætning, bedes De kontakte Deres forhandler eller vor kundeservice på [opj@opj.dk](mailto:opj@opj.dk)

### **Placering**

Vælg et solrigt sted, hvor der er mest muligt læ. Undgå at placere drivhuset på steder, hvor der kan opstå turbulens pga. nærtstående bygninger.

### **Vigtigt**

Før De begynder at samle Deres drivhus, kontroller venligst efter indholdsfortegnelsen, at alle dele er medleveret. Tag de enkelte bundter ud af kassen for bedre at kunne kontrollere indholdet. Undgå så vidt muligt at åbne delpakkerne, før De når til det pågældende punkt i vejledningen.

Numrene på bundterne stemmer overens med nummereringen i monteringsvejledningen.

Det er vigtigt ikke at blande åbnede bundter.

Hvis der mangler noget, kontakt venligst Deres forhandler.

Såfremt De mener, at en del ikke passer, må De under ingen omstændigheder begynde at tilpasse denne del ved at bore eller save i aluminiumsprofilerne. Kontakt i stedet vor kundeservice på [opj@opj.dk](mailto:opj@opj.dk), der vil hjælpe Dem videre.

Vi forbeholder os ret til at foretage tekniske ændringer af produktet og dets specifikationer, hvilket kan medføre ændringer i vejledningerne.

På vor hjemmeside vil De altid kunne finde den nyeste udgave af monteringsvejledningen. Såfremt denne måtte afvige væsentligt fra Deres produkt, er De velkommen til at kontakte vor kundeservice på [opj@opj.dk](mailto:opj@opj.dk). De kan identificere Deres udgave af vejledningen ved hjælp af det nummer, der er anført nederst på alle sider i vejledningen.

### **Nødvendigt værktøj (indgår ikke i leverancen):**

- Skruetrækker (stjerne PH2 og PZ2)
- 1 målebånd/tommestok
- 1 skævbider
- Akku-boremaskine med moment
- 1 vaterpas
- 1-2 trappetiger
- 1x10 mm fastnøgle.
- 1 hobbykniv
- 1x10 mm gaffelnøgle
- 1 gummihammer

- **De bør altid bruge handsker, når De arbejder med polycarbonatplader eller glas. Skarpe kanter kan forårsage skader. Der kan også forekomme skarpe kanter på kanter og hjørner på aluminiumsprofiler. Her bør De også bære handsker. Ved isætning af glas bør De også anvende beskyttelsesbriller, sikkerhedssko og hovedbeskyttelse (sikkerhedshjelm). Itugået glas udgør en sikkerhedsrisiko og bør bortskaffes med forsigtighed.**
- **NB! Udvis forsigtighed ved glasmontage. Glasset kan splintre under monteringen.**
- **Bær gerne sikkerhedsbriller, medens glasset monteres.**
- **Samling af drivhuset og montering af glas bør ikke foretages i stærk blæst eller storm.**
- **Efter ca. 2 uger efterspændes alle bolte uden at overspænde disse.**



**Læs hele monteringsvejledningen, inden samlingen af drivhuset påbegyndes.**

Drivhuset bør lejlighedsvis rengøres grundigt med et mildt rengøringsmiddel. Glasset kan rengøres med et hvilket som helst rengøringsmiddel, der ikke skader aluminiumsprofiler eller glasholdere og clips, f.eks. Vitavia drivhusrens eller brun sæbe. Test eventuelt på et mindre område, hvis De er i tvivl.

Dørskinnerne bør regelmæssigt rengøres og smøres med stearin/grafitolie.

Ved snefald fjernes sneen fra taget, således at der ikke opstår risiko for skader som følge af snebelastningen af glas og profiler. Ved kraftigt snefald og ved skiftevis tø- og frostvejr skal sne fjernes hurtigst muligt fra taget.

Ved risiko for kraftigt snefald understøttes tagryggen med en stolpe eller lign.

Ved kraftig blæst skal alle vinduer og døre lukkes. Afmonter / deaktiver eventuelle automatiske vinduesåbnere.

### **Anmærkning**



**Vi anbefaler, at De sørger for, at Deres husforsikring også dækker Deres drivhus. Overhold alle byggevedtægter. Kontakt Teknisk Forvaltning i Deres kommune, hvis De er i tvivl.**

**Typebetegnelsen skal De bruge ved bestilling af evt. reservedele, så opbevar venligst montagevejledningen til senere brug.**











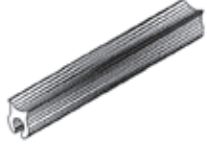



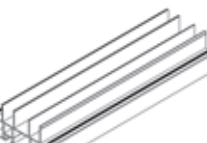





**Skulle De få problemer med drivhusmontagen eller glasisætning, bedes De kontakte Deres forhandler eller vor kundeservice på [opj@opj.dk](mailto:opj@opj.dk)**

**Følg de beskrevne arbejdsgange meget omhyggeligt. Såfremt De mener, at der skulle være fejl ved produktet eller i vejledningen, eller hvis noget er uklart, er De velkommen til at kontakte os på [opj@opj.dk](mailto:opj@opj.dk) - kunder i Norge bedes kontakte vor importør Grønn Industri. Vi forsøger løbende at opdatere vore vejledninger og modtager gerne input via e-mail.**

Kontroller først om De har modtaget det korrekte antal delpakker passende til Deres model ved hjælp af nedenstående oversigtstabel.













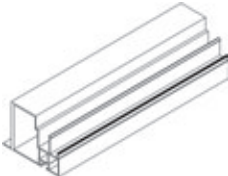

Model	Pakke 1-1	Pakke 1-2	Pakke 2	Pakke 3	Pakke 4	Pakke 5
7800	1	1	2			
9600	1	1	1	1		
11500	1	1		2		1
13500	1	1	2	1	1	
15300	1	1	1	2	1	

Kode nr.	Pakke 1-1				Antal stk. / Model			Profil
	Artikel	Montage-trin	Længde i mm	Antal i delpakke	13500	15300		
6090		7bc	56000	1	103500	112000		
7005		3	1775	2	10	12		
7006		2	1775	3	5	5		
7014		2	1775	1	1	1		
7015		6b	1000	1	1	1		
7017		6a	717	1	1	1		
7018		6a	717	1	1	1		
7030		7b	1793	2	2	2		
7032		7b	1793	2	10	12		

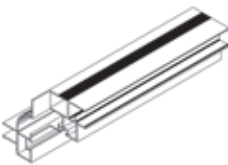
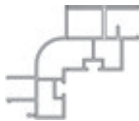
# Stykliste

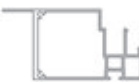
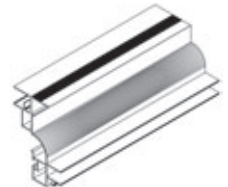
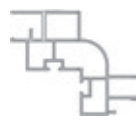
ZEUS













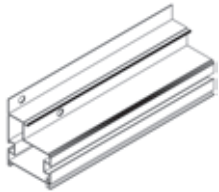

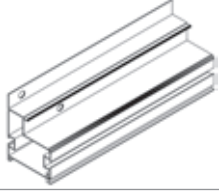

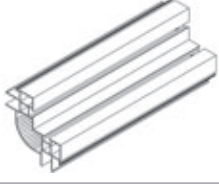
# Stykliste

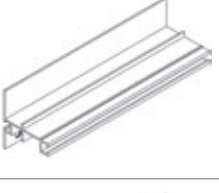
Kode nr.	Pakke 1-1				Antal stk. / Model			Profil
	Artikel	Montage-trin	Længde i mm	Antal i delpakke	13500	15300		
7033		7b	1793	14	18	18		
7045		2	1775	1	1	1		
7069		3	1924	4	4	4		
7083		6ab	900	2	2	2		
7212		4a	1354.7	2	2	2		
7216		6b	1000	1	1	1		
7228		4a	1354.7	2	2	2		
7268		4a	1527.5	4	4	4		
7269		3	1926	4	4	4		

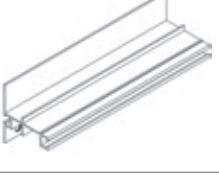
ZEUS

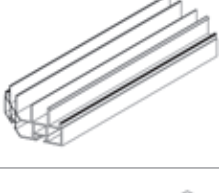

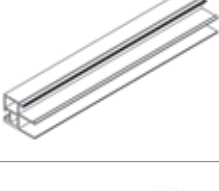
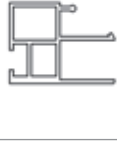
# Stykliste

Kode nr.	Pakke 1-2				Antal stk. / Model			Profil
	Artikel	Montage-trin	Længde i mm	Antal i delpakke	13500	15300		
7000		1		4	4	4		
7003		1	1230	2	2	2		
7004		1	1230	2	2	2		
7007		1	1775	4	4	4		
7010		2	1230	2	2	2		
7011		2	1230	2	2	2		
7019		3	567	2	2	2		
7022		6ab	708	4	4	4		
7023		6b	850	1	1	1		

ZEUS









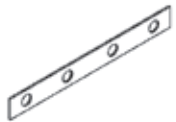

# Stykliste

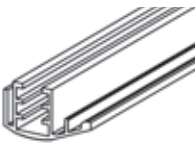
Kode nr.	Pakke 1-2				Antal stk. / Model			Profil
	Artikel	Montage-trin	Længde i mm	Antal i delpakke	13500	15300		
7024		6a	850	1	1	1		
7025		6ab	850	2	2	2		
7031		7c	996	2	2	2		
7034		7bc	733	8	22	24		
7035		7c	713	2	2	2		
7036		7b	922	1	1	1		
7044		7b	443	2	2	2		
7048		4b	M6 x 80	2	2	3		
7050		7b	M6 x 40	96	172	184		





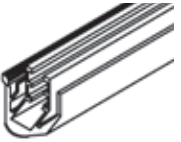

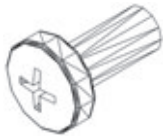
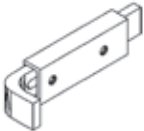

ZEUS

Pakke 1-2					Antal stk. / Model			Profil
Kode nr.	Artikel	Montage-trin	Længde i mm	Antal i delpakke	13500	15300		
7052		1,2,3, 4ab,5 6ab,7a	M6 x 12	100	248	268		
7053		1,2,3, 4ab,5 6ab,7	M6 x 4	218	442	474		
7054		4b,6ab	M6 x 100	8	14	14		
7055		4b, 6ab	M6x10x14	8	14	14		
7056		8	3.9 x 13	4	4	4		
7057		5,4b, 6ab	3.5 x 6	20	36	36		
7058		7c	M6 x 34	22	22	22		
7061		1,2, 4a,7a	117	9	22	22		
7062		4ab	235	4	10	11		

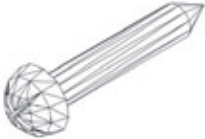
# Stykliste



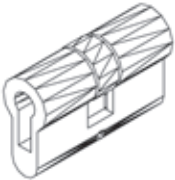





Kode nr.	Pakke 1-2				Antal stk. / Model			Profil
	Artikel	Montage-trin	Længde i mm	Antal i delpakke	13500	15300		
7063		3	255	4	16	18		
7064		1,2, 4a,7a	117	5	16	16		
7065		4a	140	2	4	4		
7066		6ab	75	4	4	4		
7074		7b	1369	2	2	2		
7075		7b	1369	2	2	2		
7076		7b	570	2	2	2		
7077		7b	570	2	2	2		
7080		1,2, 4a,7a	M6 x 8	36	88	88		

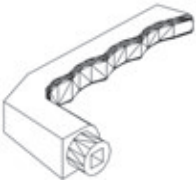

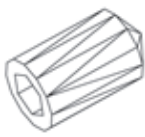

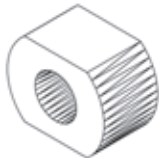

# Styklister

Pakke 1-2					Antal stk. / Model			Profil
Kode nr.	Artikel	Montage-trin	Længde i mm	Antal i delpakke	13500	15300		
7081		4a	M5 x 13	4	8	8		
7085		6a	95	1	1	1		
7086		6b	23	1	1	1		
7087		6a	5 x 30	2	2	2		
7088		6ab	3.9 x 13	30	30	30		
7095		1	117	4	6	6		
7100		6b	244	1	1	1		
7101		6b	62	1	1	1		
7102		6b	M5 x 35	1	1	1		

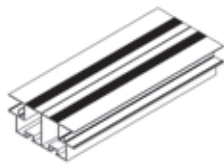
ZEUS

# Styklister







Kode nr.	Pakke 1-2				Antal stk. / Model			Profil
	Artikel	Montage-trin	Længde i mm	Antal i delpakke	13500	15300		
7103		6b	65	2	2	2		
7104		6b	125	2	2	2		
7106		6b	Ø 27	2	2	2		
7107		6b	100	1	1	1		
7108		6b	4.7 x 8	2	2	2		
7110		8	100	1	1	1		
7111		8	35	1	1	1		
7112		8	8	2	2	2		
7207		7a	100	2	4	4		

Pakke 1-2					Antal stk. / Model			Profil
Kode nr.	Artikel	Montage-trin	Længde i mm	Antal i delpakke	13500	15300		
7226		4a	1333	2	4	4		
7249		4b	1251	1	6	7		
7267		8		2	2	2		
7270		8		2	2	2		
7271		8		2	2	2		

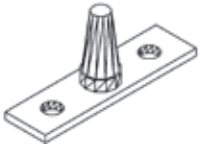
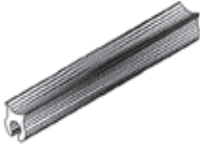

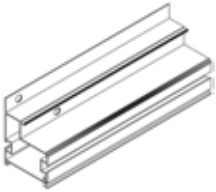
# Styklister

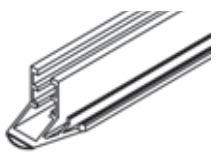
ZEUS

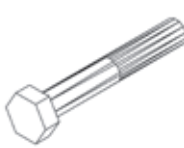









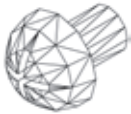

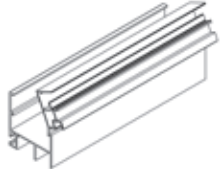

# Stykliste

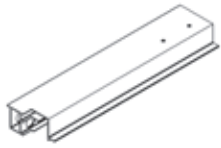

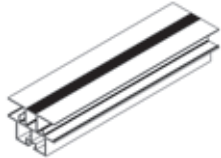
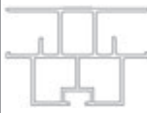

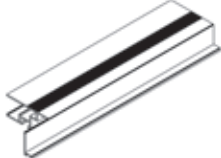
Kode nr.	Pakke 2				Antal stk. / Model			Profil
	Artikel	Montage-trin	Længde i mm	Antal i delpakke	13500	15300		
6056		4b	47	2	6	6		
6090		7bc	10500	1	103500	112000		
7001		1	1520	2	4	2		
7005		3	1775	2	10	12		
7013		4a	1520	1	2	1		
7032		7b	1793	2	10	12		
7034		7bc	733	4	22	24		
7047		4b	M6 x 48	1	4	5		
7050		7b	M6 x 40	19	172	184		



Pakke 2					Antal stk. / Model			Profil
Kode nr.	Artikel	Montage-trin	Længde i mm	Antal i delpakke	13500	15300		
7052		1,2,3, 4ab,5 6ab,7a	M6 x 12	31	248	268		
7053		1,2,3, 4ab,5 6ab,7	M6 x 4	50	442	474		
7054		4b,6ab	M6 x 100	2	14	14		
7055		4b,6ab	M6x10x14	2	14	14		
7057		5,4b, 6ab	3.5 x 6	6	36	36		
7061		1,2, 4a,7a	117	3	22	22		
7062		4ab	235	1	10	11		
7063		3	255	2	16	18		
7064		1,2, 4a,7a	117	3	16	16		

# Stykliste











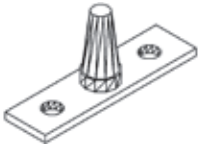
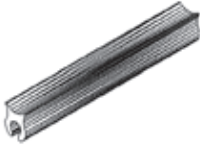

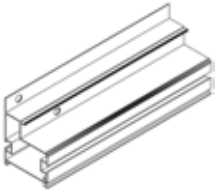

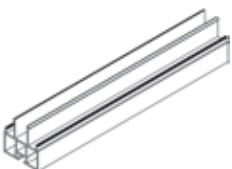
Kode nr.	Pakke 2				Antal stk. / Model			Profil
	Artikel	Montage-trin	Længde i mm	Antal i delpakke	13500	15300		
7080		1,2, 4a,7a	M6 x 8	12	88	88		
7090		5	324	1	3	3		
7208		2	1520	2	4	2		
7210		7a	1520	2	4	2		
7220		4b	708	1	3	3		
7227		4b	1333	2	8	10		
7241		5	713	1	3	3		
7242		5	667	2	6	6		
7243		5	713	1	3	3		

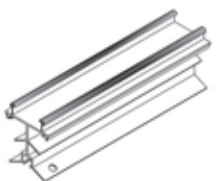



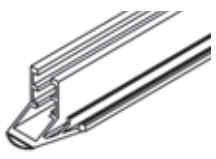



Pakke 2					Antal stk. / Model			Profil
Kode nr.	Artikel	Montage-trin	Længde i mm	Antal i delpakke	13500	15300		
7249		4b	1251	1	6	7		
(7291) 7242		5	667	2	6	6		

# Styklister







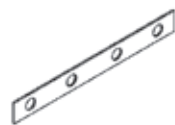



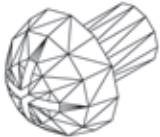

ZEUS

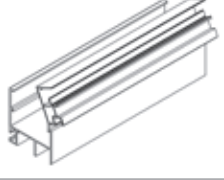
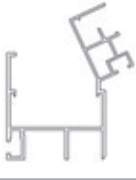
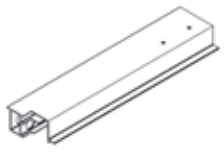
# Stykliste

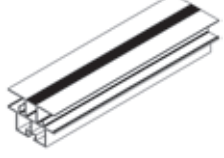
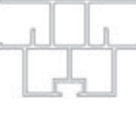
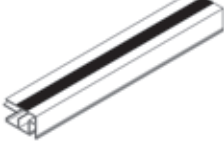



Kode nr.	Pakke 3				Antal stk. / Model			Profil
	Artikel	Montage-trin	Længde i mm	Antal i delpakke	13500	15300		
6056		4b	47	2	6	6		
6090		7bc	19000	1	103500	112000		
7002		1	2264	2	2	4		
7005		3	1775	4	10	12		
7021		4a	2264	1	1	2		
7032		7b	1793	4	10	12		
7034		7bc	733	6	22	24		
7047		4b	M6 x 48	3	4	5		
7050		7b	M6 x 40	31	172	184		

Pakke 3					Antal stk. / Model			Profil
Kode nr.	Artikel	Montage-trin	Længde i mm	Antal i delpakke	13500	15300		
7052		1,2,3, 4ab,5 6ab,7a	M6 x 12	51	248	268		
7053		1,2,3, 4ab,5 6ab,7	M6 x 4	82	442	474		
7054		4b,6ab	M6 x 100	2	14	14		
7055		4b,6ab	M6x10x14	2	14	14		
7057		4b,5 6ab	3.5 x 6	6	36	36		
7061		1,2, 4a,7a	117	3	22	22		
7062		4ab	235	2	10	11		
7063		3	255	4	16	18		
7064		1,2, 4a,7a	117	3	16	16		

# Stykliste

Kode nr.	Pakke 3				Antal stk. / Model			Profil
	Artikel	Montage-trin	Længde i mm	Antal i delpakke	13500	15300		
7080		1,2,4a,7a	M6 x 8	12	88	88		
7090		5	324	1	3	3		
7209		2	2264	2	2	4		
7211		7a	2264	2	2	4		
7220		4b	708	1	3	3		
7227		4b	1333	4	8	10		
7241		5	713	1	3	3		
7242		5	667	2	6	6		
7243		5	713	1	3	3		

ZEUS

Pakke 3					Antal stk. / Model			Profil
Kode nr.	Artikel	Montage-trin	Længde i mm	Antal i delpakke	13500	15300		
7249		4b	1251	2	6	7		
(7291) 7242		5	667	2	6	6		

# Styklister

ZEUS









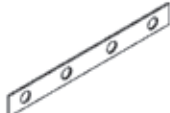

# Styklister

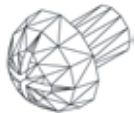
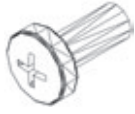
Kode nr.	Pakke 4				Antal stk. / Model		Profil
	Artikel	Montage-trin	Længde i mm	Antal i delpakke	13500	15300	
6090		7bc	7500	1	103500	112000	
7006		2	1775	2	5	5	
7033		7b	1793	4	18	18	
7048		4b	M6 x 80	2	2	3	
7050		7b	M6 x 40	13	172	184	
7052		1,2,3, 4ab,5 6ab,7a	M6 x 12	41	248	268	
7053		1,2,3, 4ab,5 6ab,7	M6 x 4	54	442	474	
7061		1,2, 4a,7a	117	4	22	22	
7062		4ab	235	2	10	11	

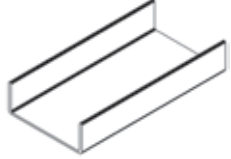
ZEUS

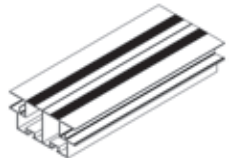

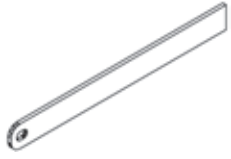







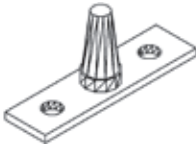





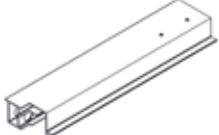

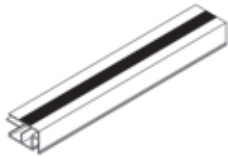
# Stykliste

Pakke 4					Antal stk. / Model			Profil
Kode nr.	Artikel	Montage-trin	Længde i mm	Antal i delpakke	13500	15300		
7063		3	255	4	16	18		
7064		1,2, 4a,7a	117	2	16	16		
7065		1,2, 4a,7a	140	2	4	4		
7080		1,2, 4a,7a	M6 x 8	16	88	88		
7081		4a	M5 x 13	4	8	8		
7095		1	117	2	6	6		
7207		6b	100	2	4	4		
7226		4a	1333	2	4	4		
7249		4b	1251	1	6	7		

ZEUS

# Styklister

Pakke 5 Vindue					Antal stk. / Model			Profil
Kode nr.	Artikel	Montage-trin	Længde i mm	Antal i delpakke	13500	15300		
6056		4b	47	2	6	6		
7052		1,2,3, 4ab,5 6ab,7a	M6 x 12	4	248	268		
7053		1,2,3, 4ab,5 6ab,7	M6 x 4	4	442	474		
7054		4b,6ab	M6 x 100	2	14	14		
7055		4b,6ab	M6x10x14	2	14	14		
7057		4b,5, 6ab	3.5 x 6	6	36	36		
7090		5	324	1	3	3		
7220		4b	708	1	3	3		
7241		5	713	1	3	3		

Pakke 5 Vindue					Antal stk. / Model			Profil
Kode nr.	Artikel	Montage-trin	Længde i mm	Antal i delpakke	13500	15300		
7242		5	667	2	6	6		
7243		5	713	1	3	3		
(7291) 7242		5	667	2	6	6		

# Styklister

ZEUS



**VIGTIGT:**

Materialer eller værktøj, der skal anvendes til fremstilling af fundamentet / soklen indgår ikke i leverancen.



Oplysninger vedr. fundamentet er vejledende.

**Drivhuset skal opstilles på et stabilt fundament / sokkel. Soklen kan laves f.eks. som en fuldstøbt betonsokkel eller bygges op i mursten eller Leca-sten.**

**Soklen skal gå ned i frostfri dybde (80-90 cm) for at undgå skævvridninger.**

**Såfremt De er usikker på soklens konstruktion, anbefaler vi Dem at kontakte en fagmand.**

**Sokkelmålene fremgår af tabellen på side 29. Vær opmærksom på, at der til senere fastgørelse af bundramme skal være 50 mm plads enten på yder- eller på indersiden af bundrammen, se illustrationen på side 29.**



**VIGTIGT:**

**Soklen skal være meget nøjagtigt i vater og de fire hjørner skal være retvinklede. Anvend et langt vaterpas og en stor vinkel til dette.**

**Tip: Sørg for, at de to X-mål som vist på tegningen side 29 er helt ens. Dermed er De sikker på, at de fire hjørner er retvinklede.**

**Byg derefter drivhuset ovenpå det færdige fundament.**

**Bundrammen skal først fastgøres til fundamentet, når hele drivhuset er færdigmonteret, og alt er i vinkel.**

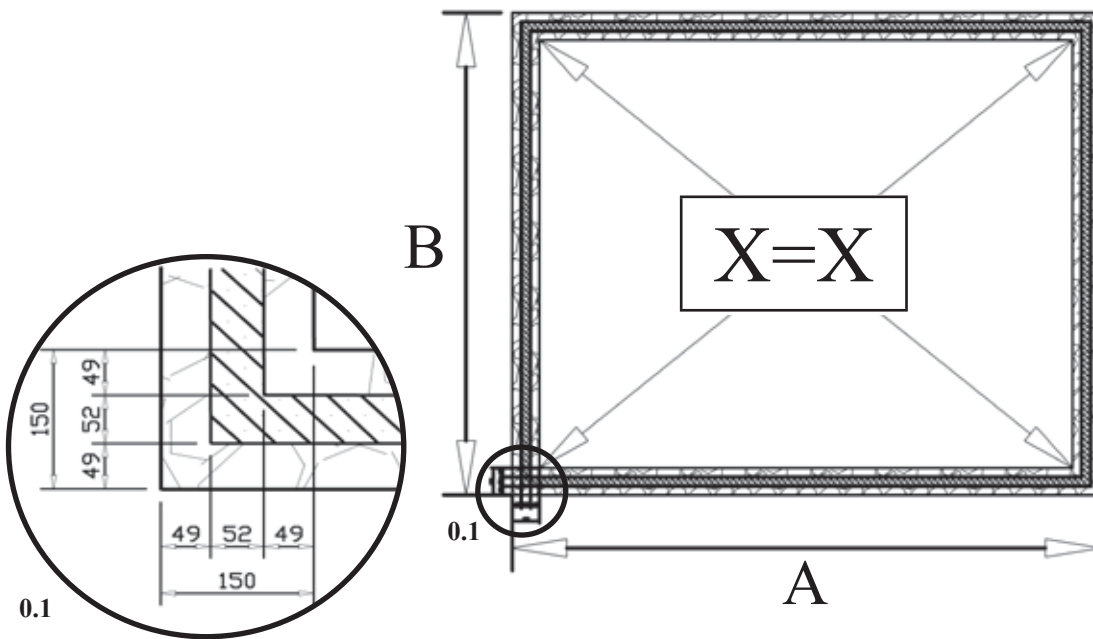
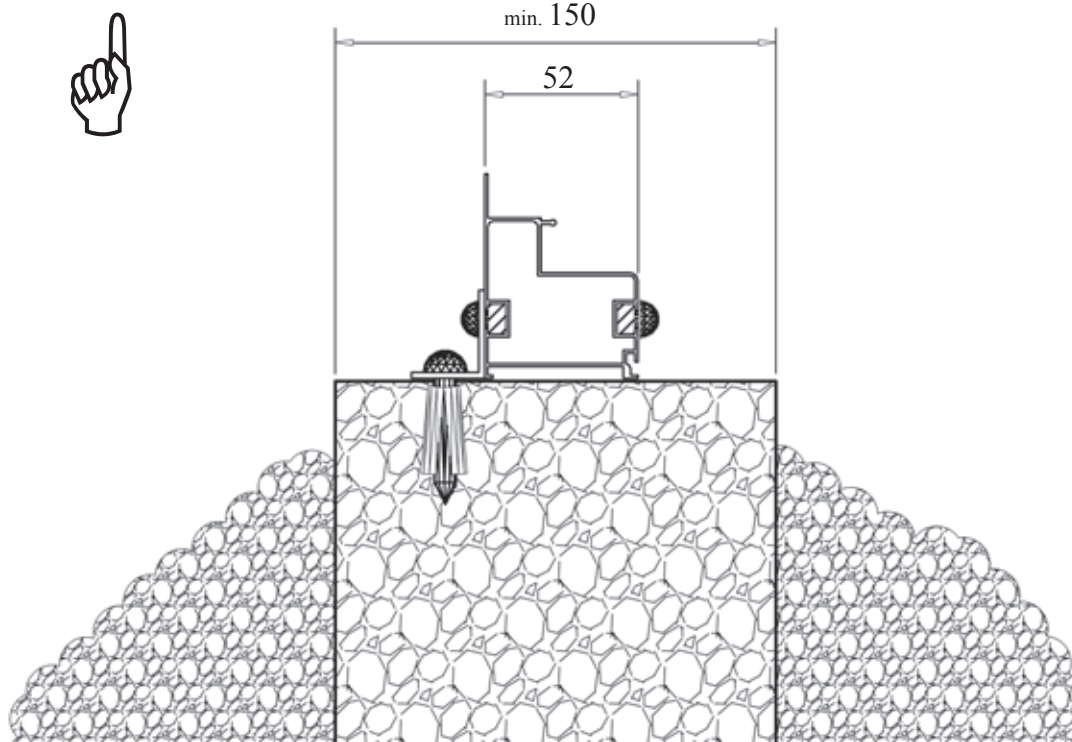

	7800	9600	11500	13500	15300
A	3242 mm	3986 mm	4730 mm	5506 mm	6250 mm
B	2662 mm	2662 mm	2662 mm	2662 mm	2662 mm

# Fundament / sokkel

# 1

Model		
13500	15300	
7000		
4	4	
7001		
4	2	
7002		
2	4	
7003		
2	2	
7004		
2	2	
7007		
4	4	
7052		
8	8	
7053		
8	8	
7061		
12	12	
7064		
6	6	
7080		
48	48	
7095		
6	6	

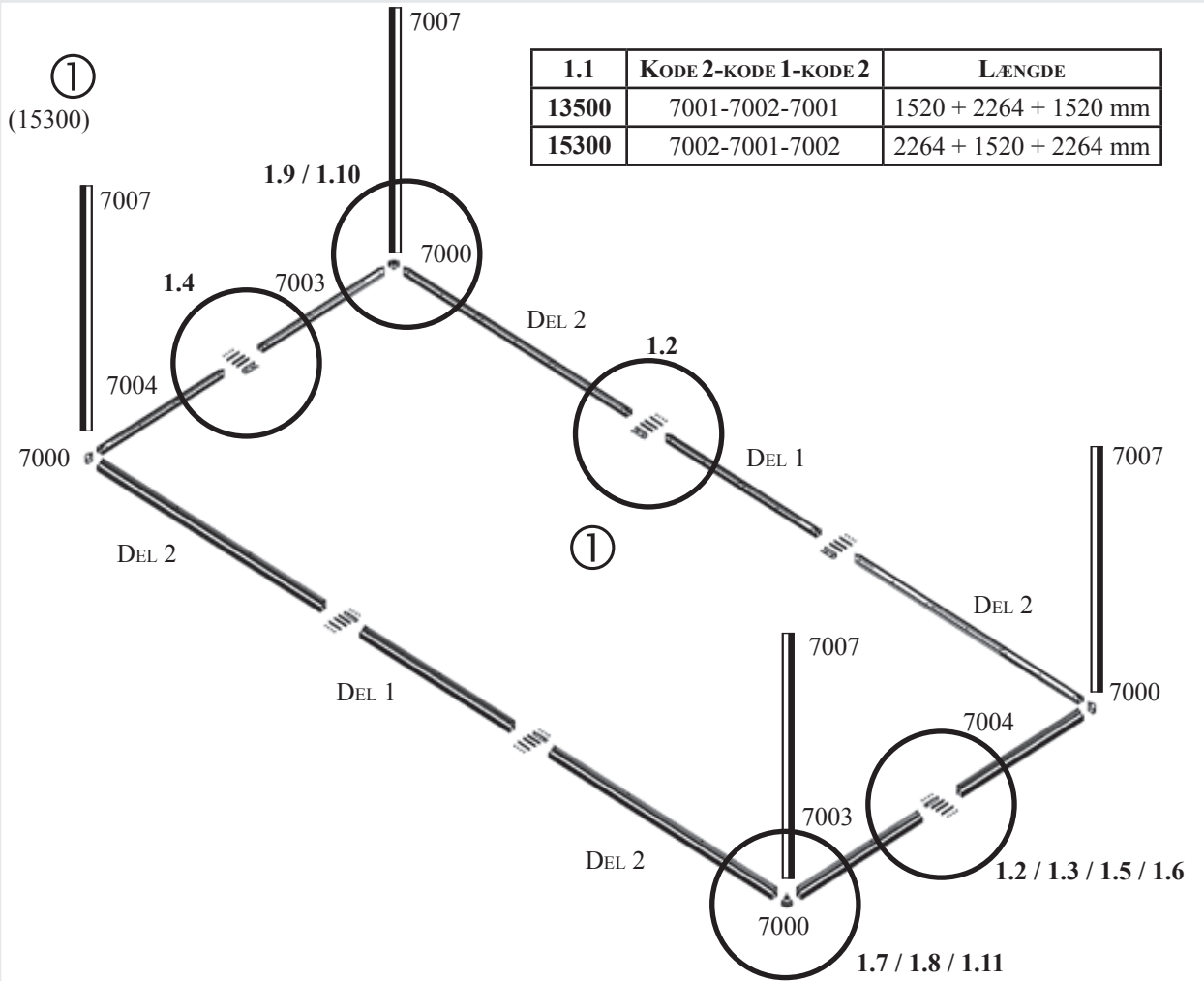

1.1	KODE 2-KODE 1-KODE 2	LÆNGDE
13500	7001-7002-7001	1520 + 2264 + 1520 mm
15300	7002-7001-7002	2264 + 1520 + 2264 mm

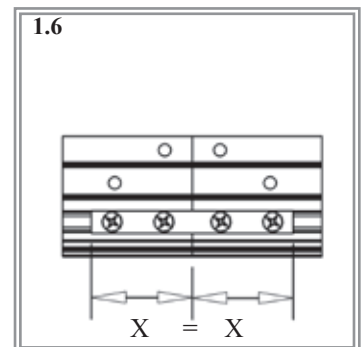
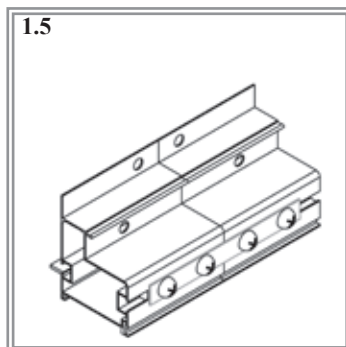
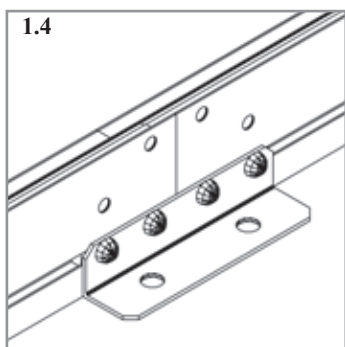
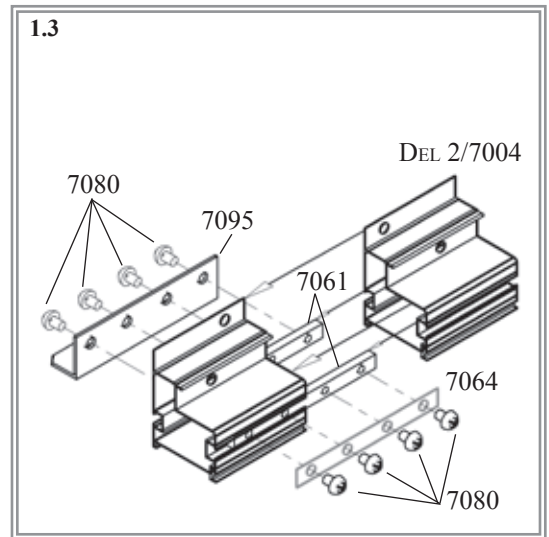
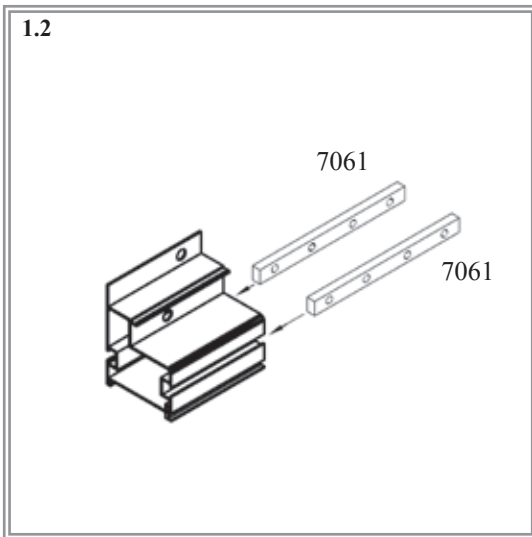

ZEUS

## BUNDRAMME OG HJØRNESTOLPER

### BEMÆRK VENLIGST:

Bundrammen skal først skrues fast på fundamentet, når alle aluminiumsprofilerne i drivhuskonstruktionen er monteret. Der bør være minimum to personer til at montere de lodrette profiler.



Tegninger med enkeltramme (f.eks. 1.9) er set indefra.

Tegninger med dobbeltramme (f.eks. 1.7) er set udefra.



(15300)

Tag bundrammeprofilerne 7001 – 7044 ud af henholdsvis profilpakke 1-2, 2 og 3 ud og læg profilerne på jorden som vist på den store ill. (1) på side 30. Dernæst 6 model-specifikke sideprofiler, se tabel (1.1) og saml disse ved hjælp af samlestykke 7061 (1.2). Ved hjælp af bolt 7080 (1.3) fastspændes samlestykke 7061 og 7064 henholdsvis 7095. Samlestykkerne skal placeres i midten (1.6). Forbind bundprofil 7003 med 7004 på samme måde.

Efterfølgende forbindes bundprofilerne med de afrundede hjørnesamlebeslag 7000 (1.7/1.8) og med hjørnestolperne 7007 (1.9/1.10).

Hver hjørnestolpe fastgøres for neden med 2 bolte 7052 og to møtrikker 7053 (1.9. – 1.11). Først spændes møtrikkerne løst på, derefter føres hjørnestolperne ned over bolthovederne. Sørg for, at bolthovederne vender således, at de ubesværet kan glide ind i sporet på hjørnestolperne.

Kontroller, at profilerne danner en ret vinkel.

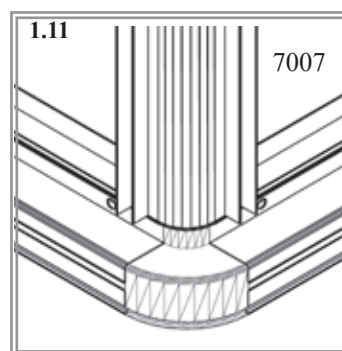
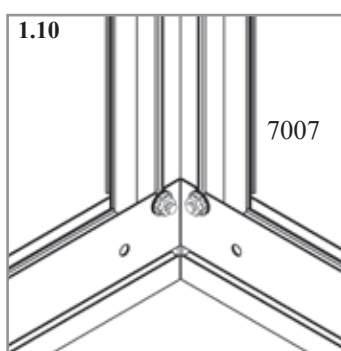
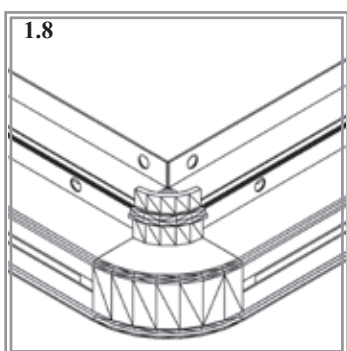
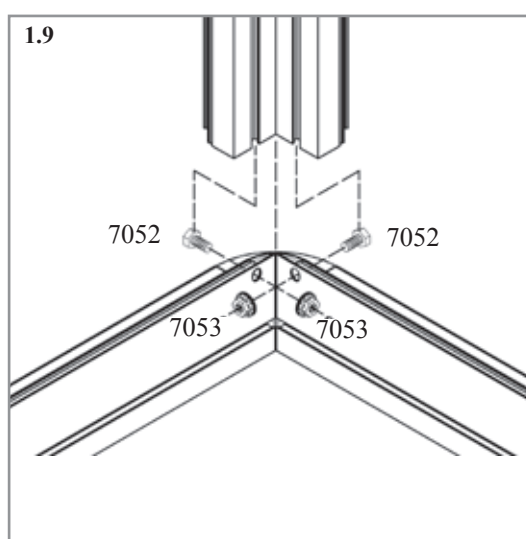
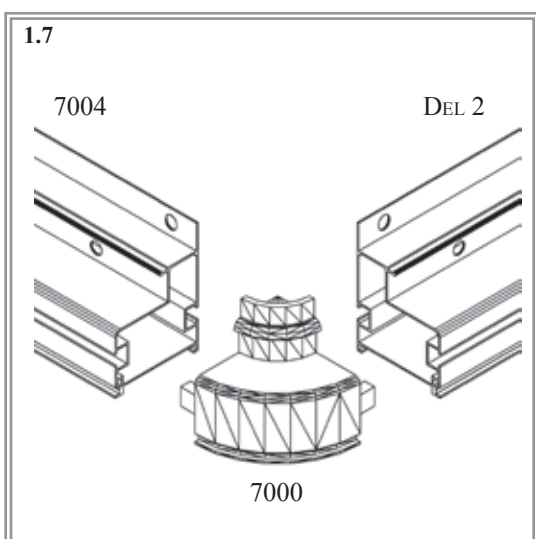

# Bundramme og hjørnestolper

ZEUS



# 2

Model	
13500	15300
7006	
5	5
7010	
2	2
7011	
2	2
7014	
1	1
7045	
1	1
7052	
48	48
7053	
48	48
7061	
4	4
7064	
4	4
7080	
16	16
7208	
4	2
7209	
2	4

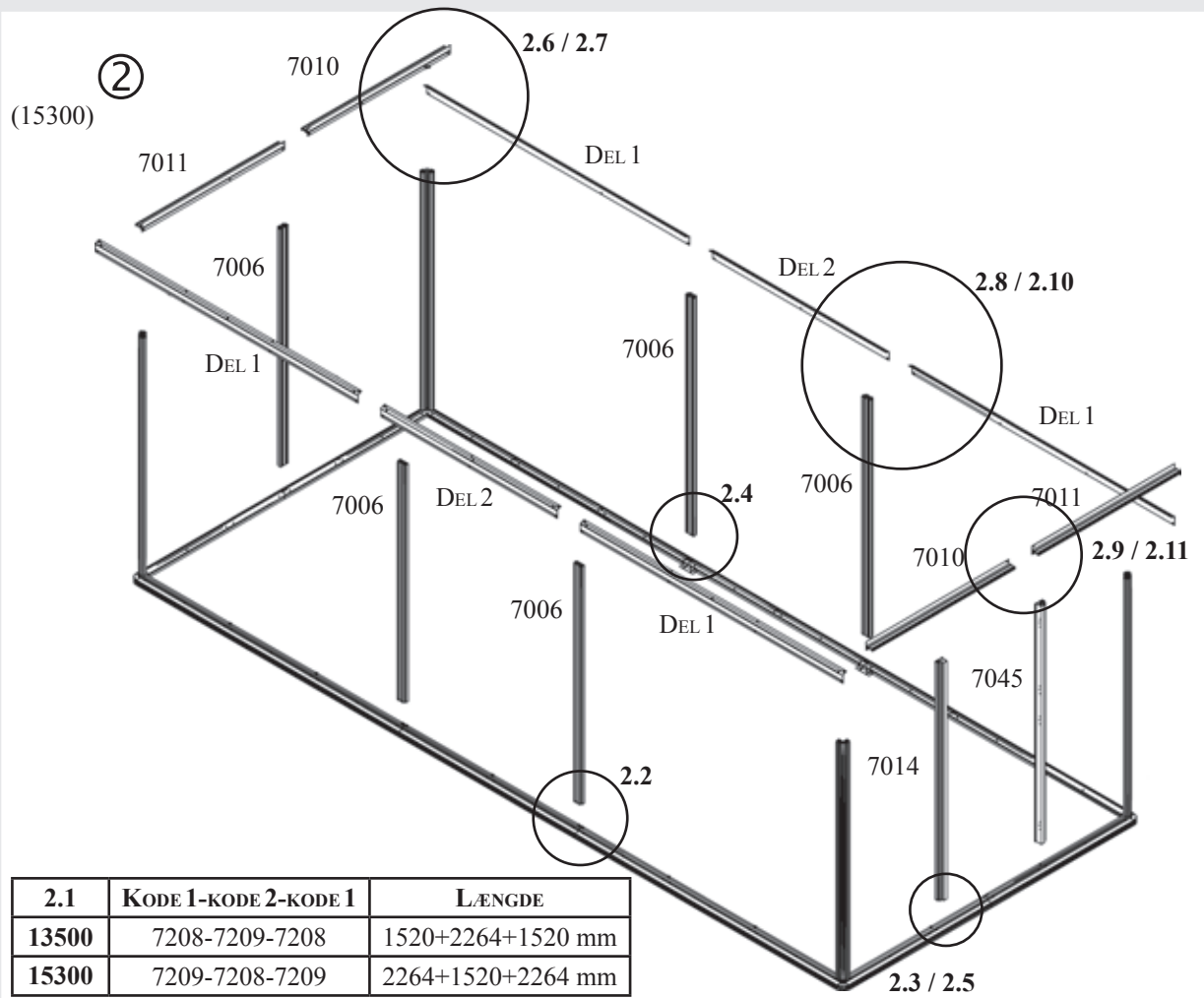

2.1	KODE 1-KODE 2-KODE 1	LÆNGDE
13500	7208-7209-7208	1520+2264+1520 mm
15300	7209-7208-7209	2264+1520+2264 mm

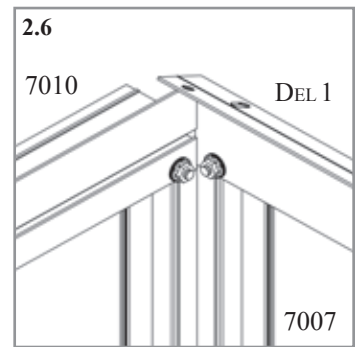
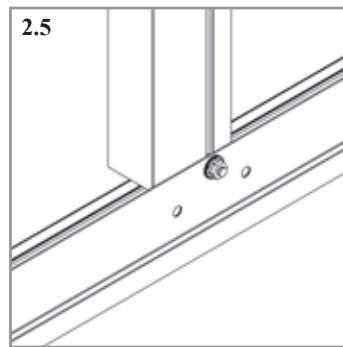
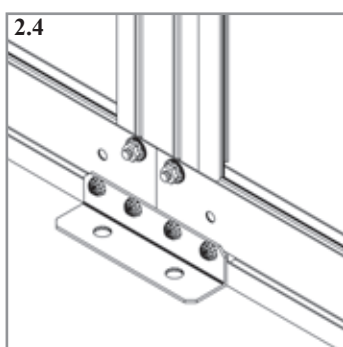
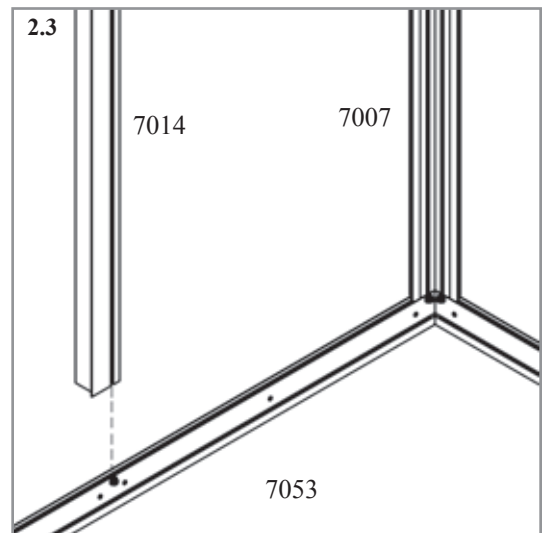
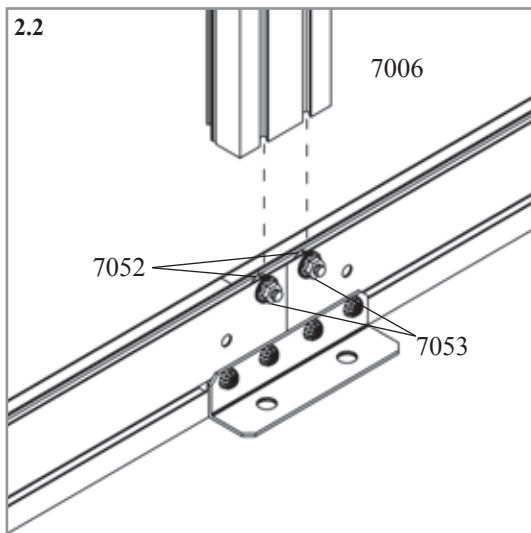

**ZEUS**



## MIDTERPROFIL / TAGREM

### BEMÆRK VENLIGST:

Til dette trin i opbygningsprocessen bør der være 2 eller 3 personer. Møtrikker skal kun spændes let. Møtrikkerne skal senere afmonteres for at muliggøre montering af yderligere profiler.

Detaljetegningerne er set indefra.

„Tombolt“ = Bolt og møtrik uden synlig funktion i starten; skal anvendes til senere fastgørelse af dele.

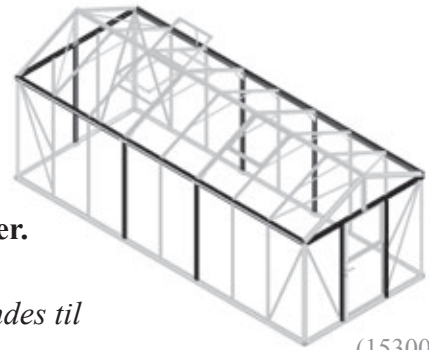

(15300)

Indsæt to tombolte 7052 i hvert bolt-spør på 4 midterprofiler 7006 og fastgør tomboltene med hver sin møtrik 7053 (2.10). Tomboltene skal senere anvendes til at fastgøre samlebeslag 7063. Ved hjælp af bolt 7052 og møtrik 7053 fastgøres profil 7006, 7014 og 7045 til bundrammen, se illustration (2.2. – 2.5). Der skal ikke en tombolt i mellemprofil 7006 på baggavlen. Fastgør langsidsens mellemprofil 7006 og hjørnestolpe 7007 til tagremmen tabel (2.1), ill. (2.7 / 2.10). Bemærk montagekanten (2.8).

De vandrette profiler 7010 og 7011 formonteres som vist på ill. 2.9. Klargør profilerne således, at disse kan samles udvendigt og indvendigt ved hjælp af hver 2 profilforbindere 7061 og 7064 og bolt 7080. Kontroller, om profilforbinderne sidder i midten som vist på (2.11). Til sidst monteres de klargjorte profiler til henholdsvis hjørne-, dør- og midterstolpen i for- og baggavl ved hjælp af bolt 7052 og møtrik 7053 (2.6 / 2.7).

# Midterprofil / tagrem

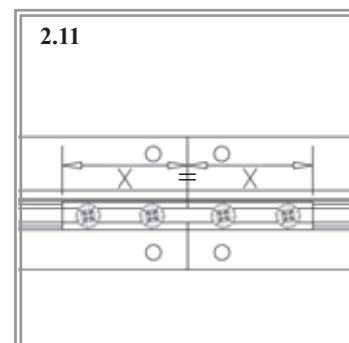
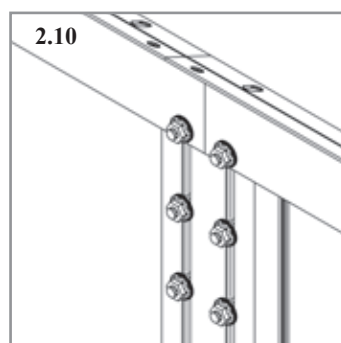
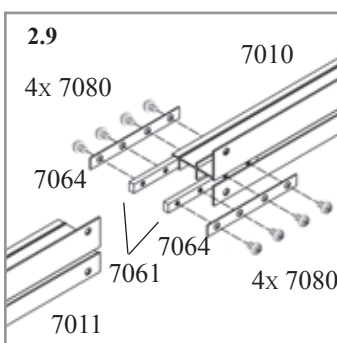
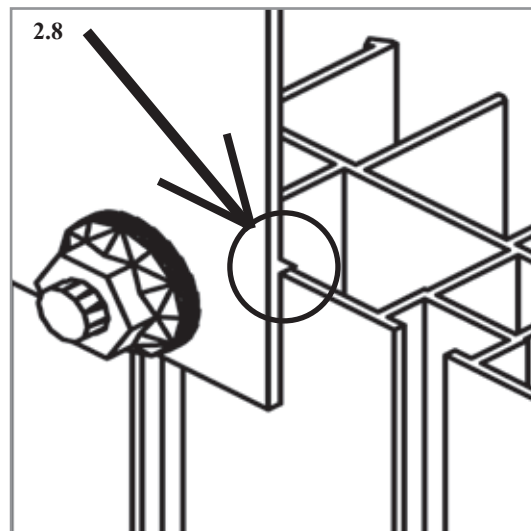
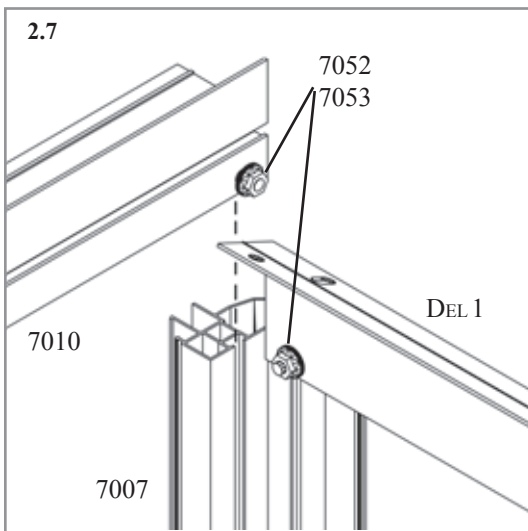

ZEUS

# 3

Model		
13500	15300	
7005		
10	12	
7019		
2	2	
7052		
44	52	
7053		
44	52	
7063		
16	18	
7069		
4	4	
7269		
4	4	

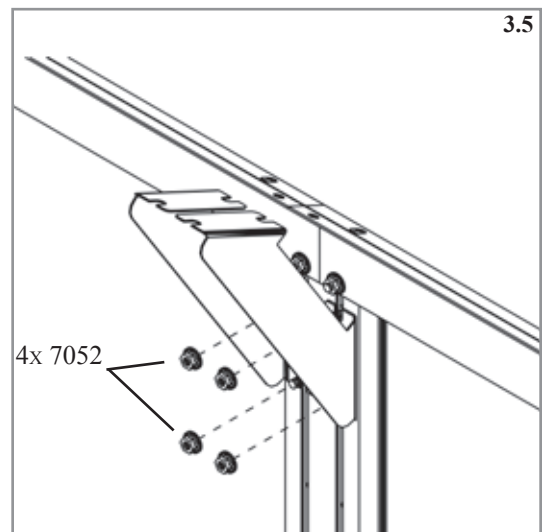
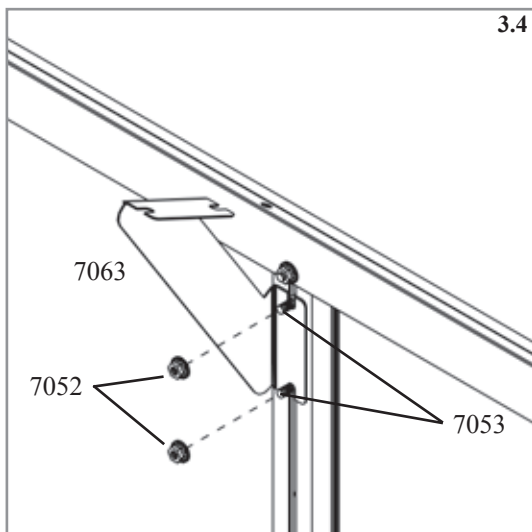
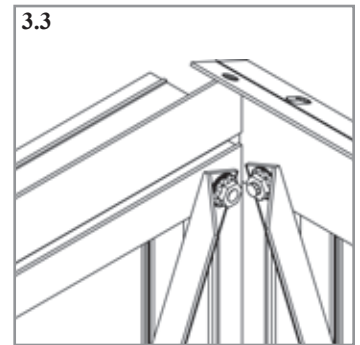
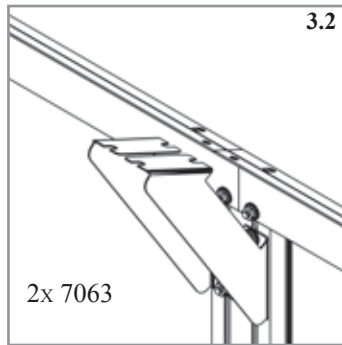
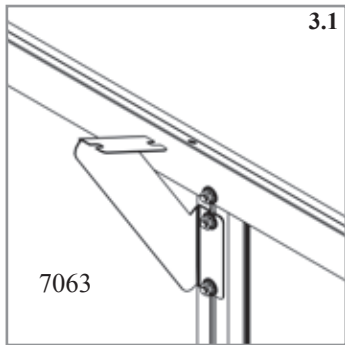
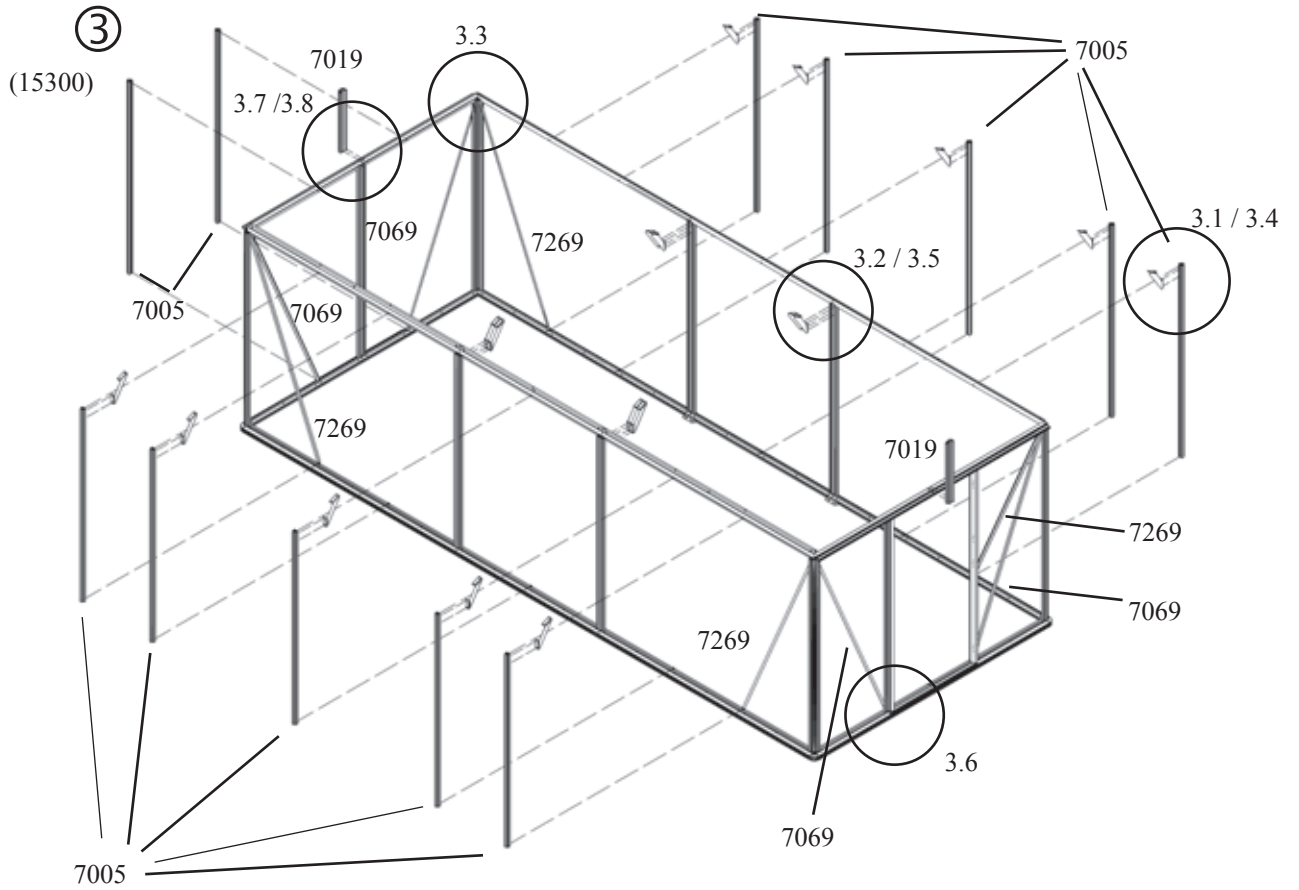

ZEUS

## MELLEMPROFILER

### BEMÆRK VENLIGST:

I denne opbygningsfase monteres vindsikringsprofilerne (de diagonale skråstivere). Allerede monterede bolte og møtrikker skal løsnes igen. Det kan forekomme, at skråstiverne synes at være for lange eller for korte. Ved at bevæge stellet (de samlede profiler) let frem og tilbage rettes huset ud, så skråstivernes længde passer.

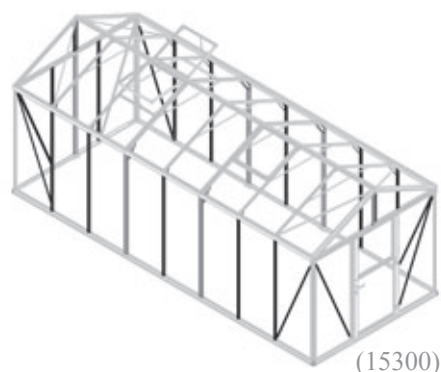







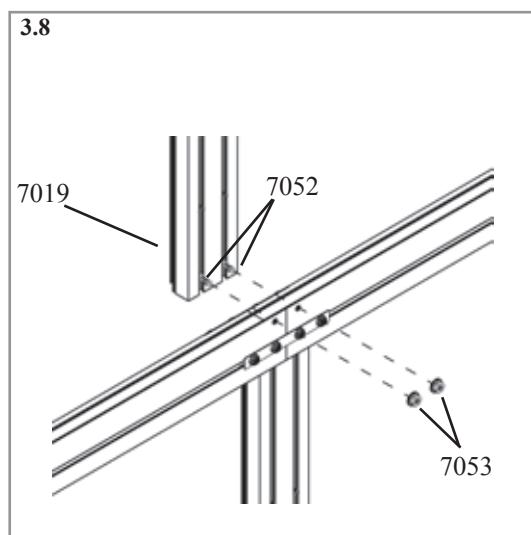
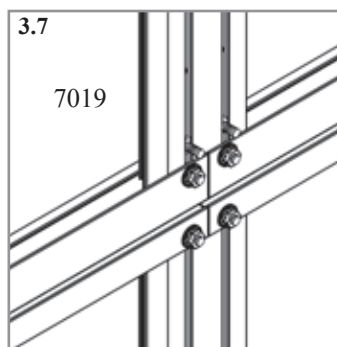
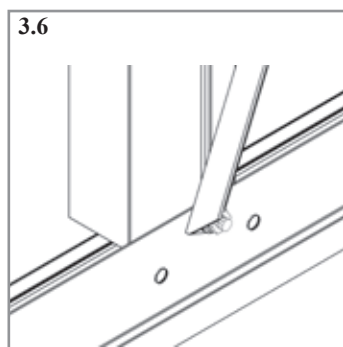







Tomboltene skal senere anvendes til at fastgøre samlebeslag 7063 til sidevæggen. Som vist på den store ill. (3) fastgøres de forberedte profiler 7005 til sidevæggen. I baggavlen monteres to mellemprofiler 7005 uden tombolte. Fastgør samlebeslag 7063 til de forberedte profiler 7005 og 7006 ved sidevæggene (3.1, 3.2, 3.4, 3.5). Samlebeslagenes nøjagtige placering (højden) afgøres først senere.

Fastgør skråstiverne 7069 og 7269 (3.3/3.6). Det kan forekomme, at skråstiverne synes at være for lange eller for korte. Ved at bevæge stellet (de samlede profiler) let frem og tilbage rettes huset ud, så skråstivernes længde passer.

Tagrygstøtterne 7019 (3.7/3.8) monteres, og der anbringes en tombolt 7052 i hvert profilspor.



# 4a

Model		
13500	15300	
7013		
2	1	
7021		
1	2	
7052		
64	64	
7053		
64	64	
7061		
2	2	
7062		
6	6	
7064		
2	2	
7065		
4	4	
7080		
8	8	
7081		
8	8	
7212		
2	2	
7226		
4	4	
7228		
2	2	
7268		
4	4	

4a.1	KODE 1-KODE 2-KODE 1	LÆNGDE
13500	7013 - 7021 - 7013	1520 + 2264 + 1520 mm
15300	7021 - 7013 - 7021	2264 + 1520 + 2264 mm

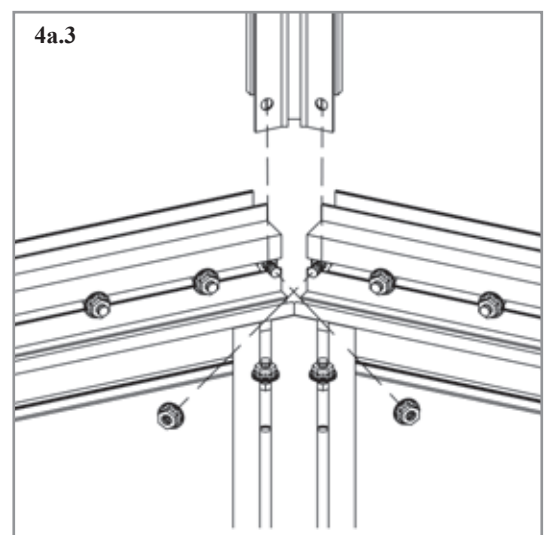
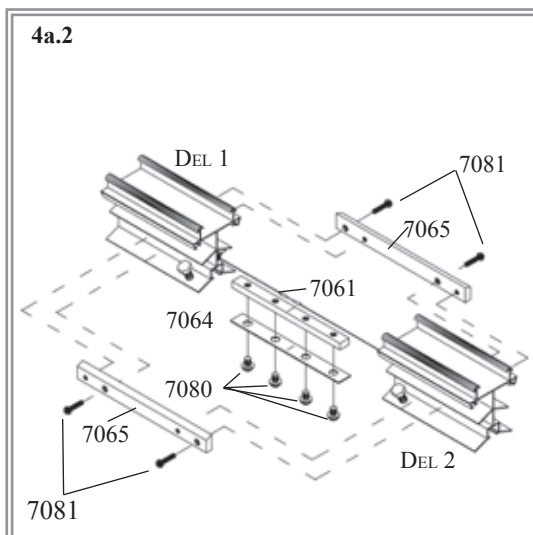
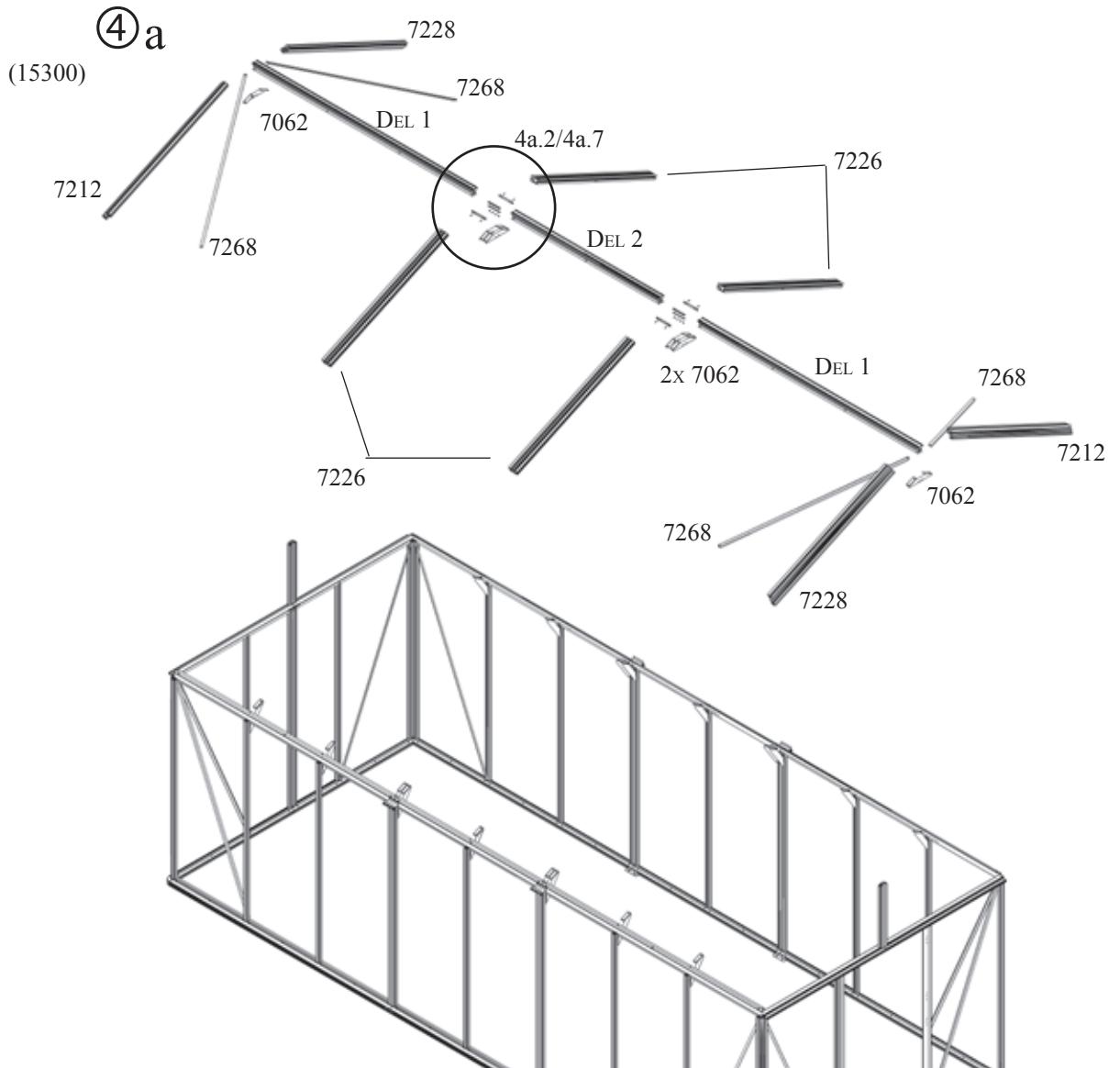

ZEUS

## TAGPROFILER / TAGRYG

### BEMÆRK VENLIGST:

Til dette trin i opbygningsprocessen bør der være to eller tre personer. De får brug for en eller gerne to stiger.

Nogle møtrikker skal løsnes for at muliggøre montering af yderligere profiler.

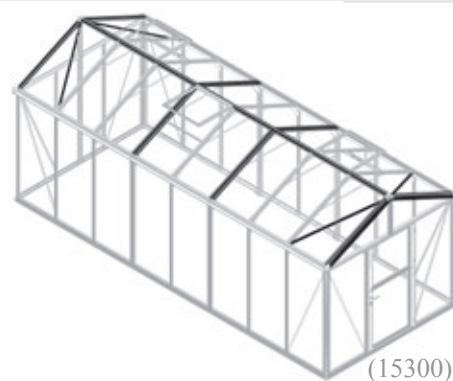

Forbered tagryggen til påsætningen ved at montere tagrygsamlebeslagene 7061, 7064 og 7065 på tagprofilerne, se tabel (4a.1), ved hjælp af boltene 7080 og 7081 som vist i (4a.2).

Læg tagryggen midlertidigt til side og sæt to tombolte 7052 i profilerne 7212 og 7228 og spænd disse let fast med møtrikker 7053 (4a.3). Disse skal senere anvendes til fastgørelse af hjørnesamlebeslag.

Anbring profil 7012 og 7028 på tagrygstøtten (4a.4) og spænd først profilen fast forneden ved tagremmen. Gentag dette trin i den modsatte gavl. Nu forbindes den klargjorte tagrygsprofil med tagprofilerne 7212 og 7228 (4a.5/4a.6). Monter rygningsslag 7062 med de formonterede tombolte. Derefter monteres diagonalstiverne 7268 (4a.6/4a.8). Forbered tagmellempprofil 7226 ved at fastgøre 4 tombolte med møtrik 7053 i hver og monter dem mellem tagryggen og tagremmen (se den store ill. 4 a). Til sidst monteres de dobbelte rygningsslag 7062 ved tagryggen og 7063 ved tagremmen (4a.7/4a.8).

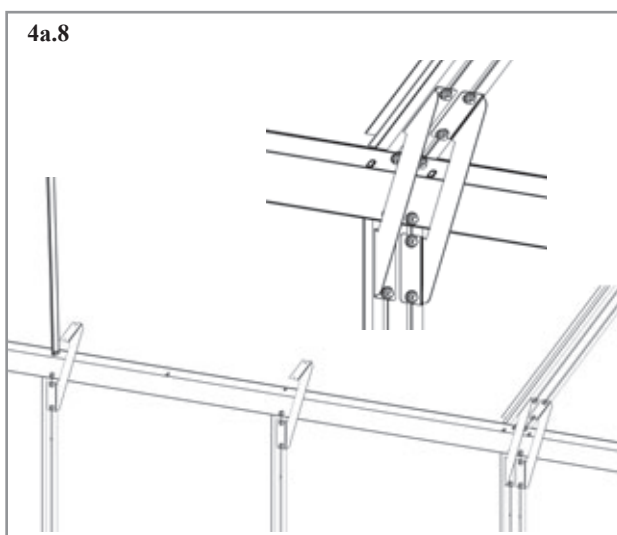
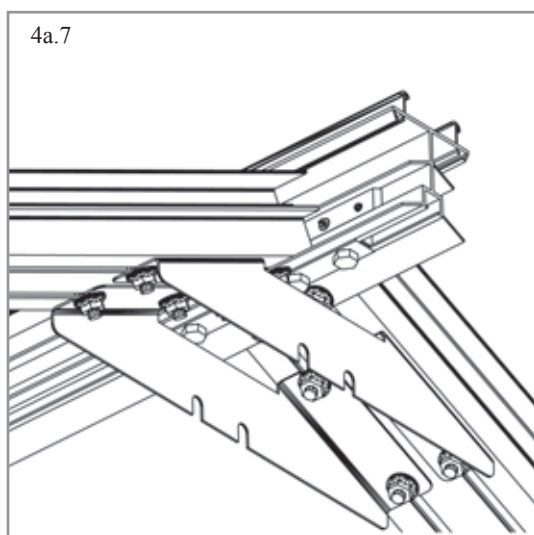
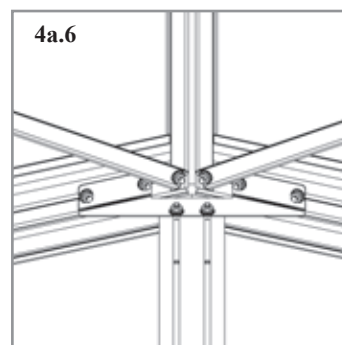
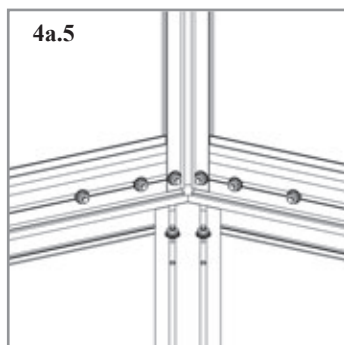
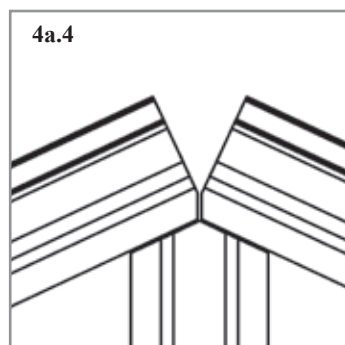



# 4b

Model		
13500	15300	
6056		
6	6	
7047		
4	5	
7048		
2	3	
7054		
6	6	
7055		
6	6	
7052		
48	60	
7053		
48	60	
7057		
12	12	
7062		
4	5	
7220		
3	3	
7227		
8	10	
7249		
6	7	

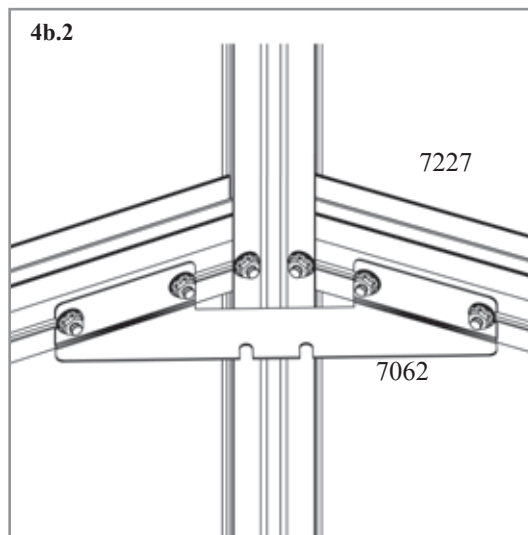
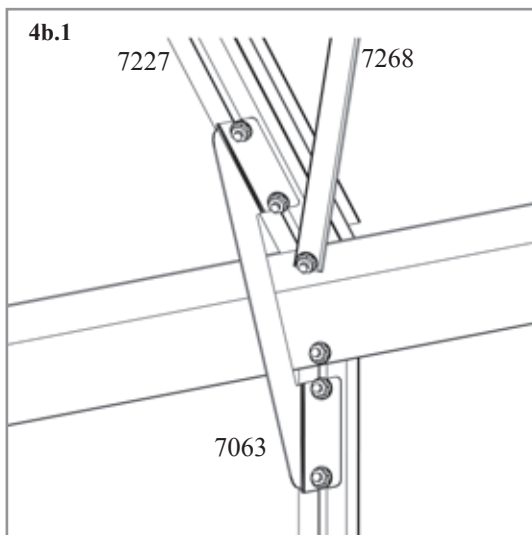
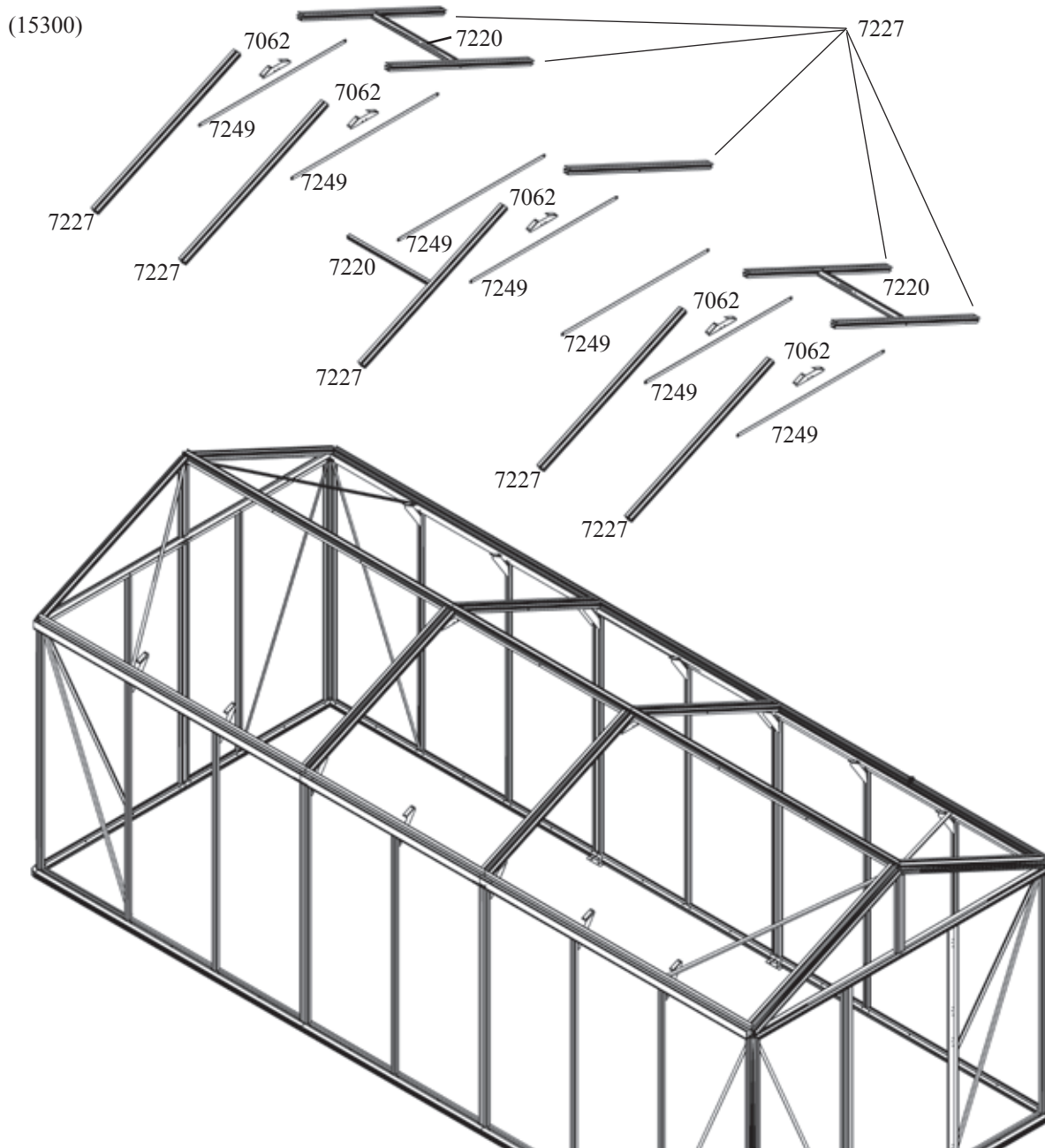

**ZEUS**

## TAGMELLEMPROFILER

### BEMÆRK VENLIGST:

Til dette trin i opbygningsprocessen bør der være to eller tre personer. De får brug for en eller gerne to stiger.

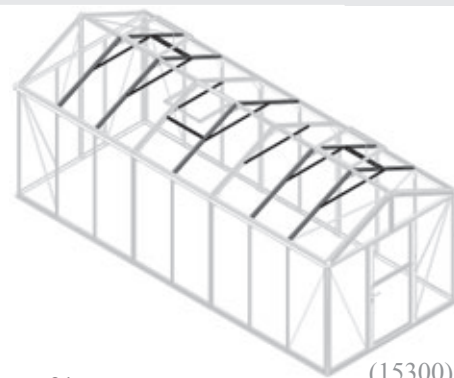

(15300)

Forbered tagmellemprofilerne 7227 ved at indføre 4 tombolte i hvert profilspor og fastgør boltene løst med møtrik 7053. Monter profilerne mellem tagryg og tagrem.

Nu monteres ryggningsbeslag 7062 (4b.2) og de allerede formonterede afstivere (4b.1) ved tagremmen.







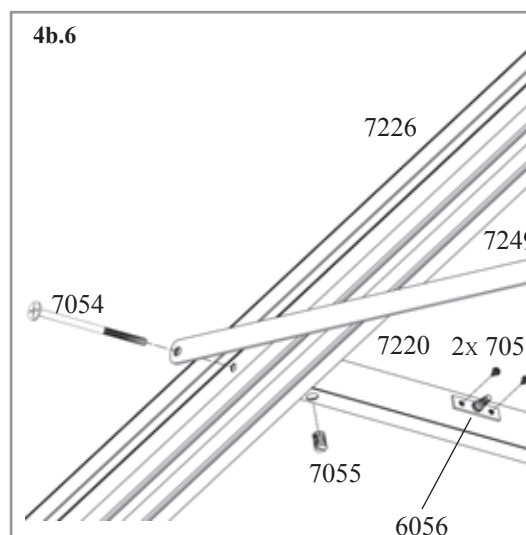
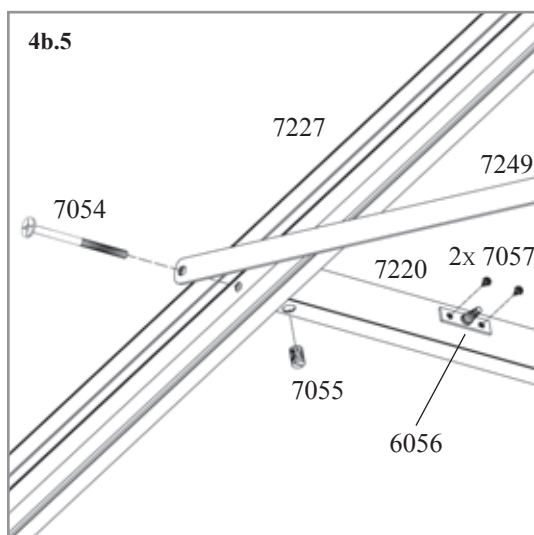
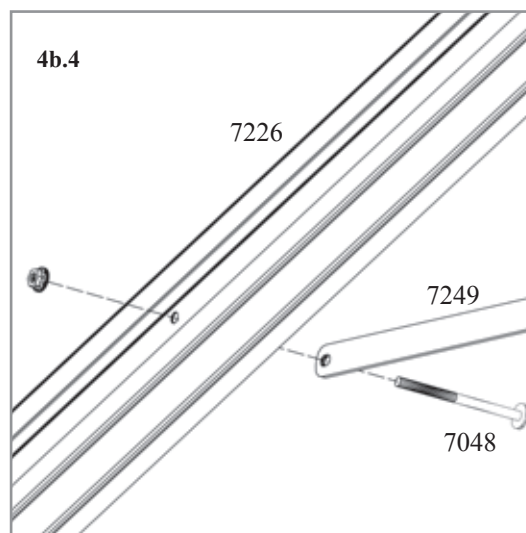
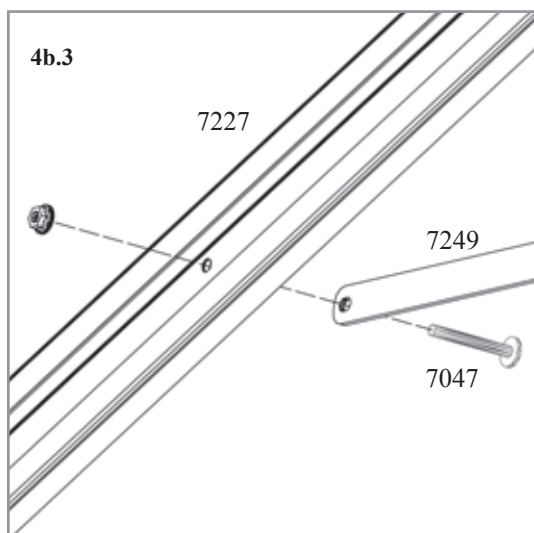

Ventilationsvinduerne kan placeres valgfrit, dog ikke i ydersektionerne eller i to nabosektioner. Vinduernes placering afgøres ved at anbringe vinduets underkarm 7220 og den vandrette afstiver 7249 i den sektion, hvor vinduet ønskes placeret.

Afhængigt af profilkombinationen er det muligt at montere vinduet på forskellige måder, se ill. (4b.3 – 4b.6).

Når vinduets underkarm 7220 er monteret kan der monteres to pløkker 6056 ved hjælp af skruer 7057.



⑤

Model		
13500	15300	
3x	3x	
7052		
3x4	3x4	
7053		
3x4	3x4	
7057		
3x2	3x2	
7090		
3x1	3x1	
7241		
3x1	3x1	
7242		
3x2	3x2	
7243		
3x1	3x1	
<b>D</b>		
3x1	3x1	

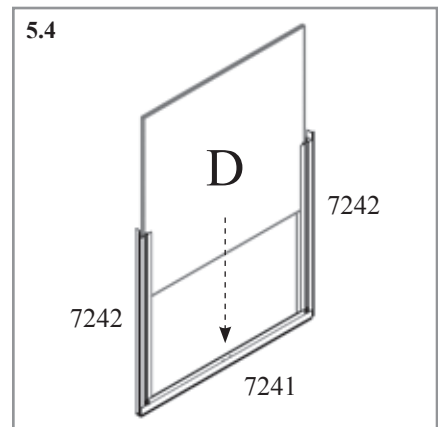
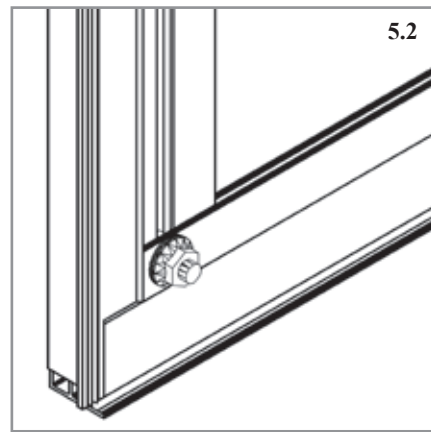
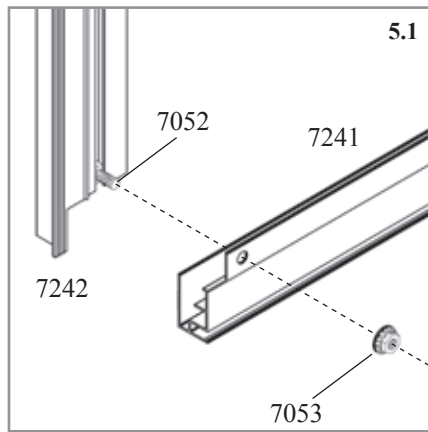
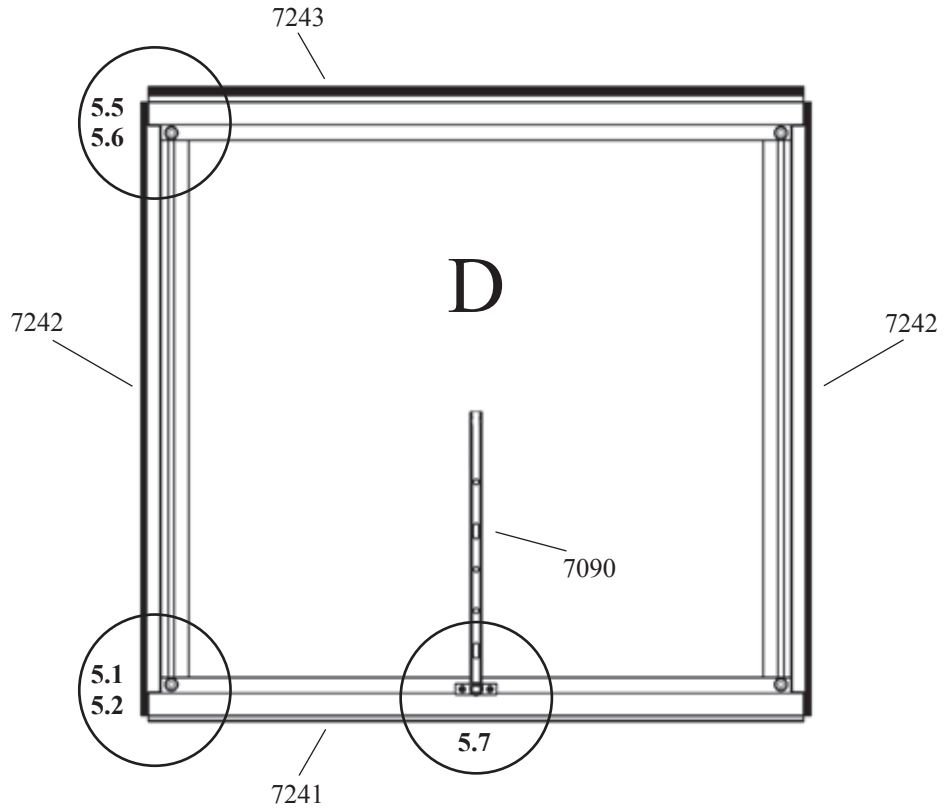

5.3	Kode nr. - Glasisætning			
	POLYCARBONATPLADER			
	10 MM		16 MM	
<b>D</b>	3695744	670 x 660	3695745	645 x 637

ZEUS



## VENTILATIONSVINDUER ( 3X )

### BEMÆRK VENLIGST:

Ved montering af ventilationsvinduet skal polycarbonatpladen isættes, inden udskyderstang 7243 monteres.

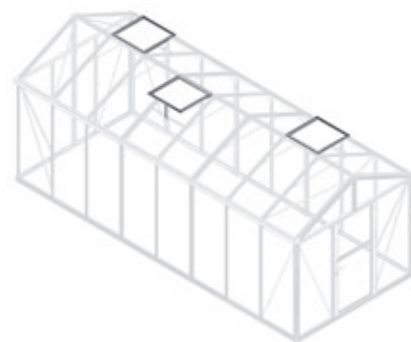

(15300)

Spænd profil 7241 og 7242 sammen ved hjælp af bolt 7051 og møtrik 7053 (5.1 – 5.2). Før polycarbonatpladen jævnfør tabel (5.3) ind i profilerne som vist i 5.4. Forbered profil 7243 ved løst at montere 2 bolte 7052 og to møtrikker 7053. Før de løst monterede møtrikker ind i profil 7242 for derved at lukke rammen (5.5 – 5.6). Vær omhyggelig med at få vinduets hjørner i rette vinkler. Til sidst monteres udskyderstang 7090 på den nederste vinduesprofil 7241 (5.7) ved hjælp af skruer 7057.

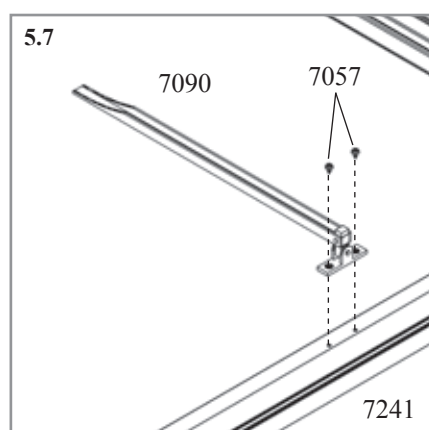
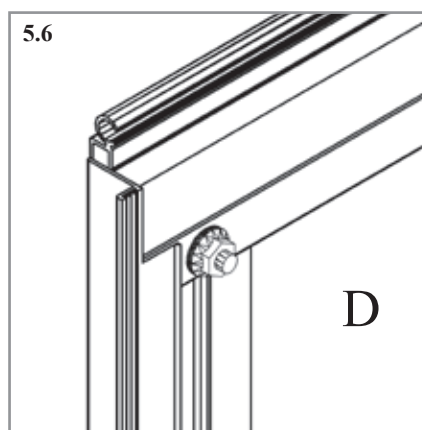
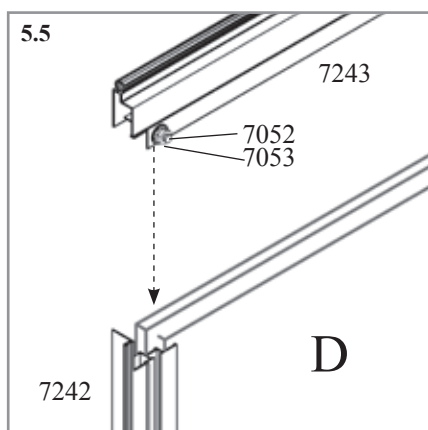

# Ventilationsvinduer

ZEUS

# 6a

⑥ a

Model	
13500	15300
7017	
1	1
7018	
1	1
7022	
2	2
7024	
1	1
7025	
1	1
7052	
2	2
7053	
2	2
7054	
4	4
7055	
4	4
7057	
10	10
7066	
2	2
7083	
1	1
7085	
1	1
7087	
2	2
7088	
6	6

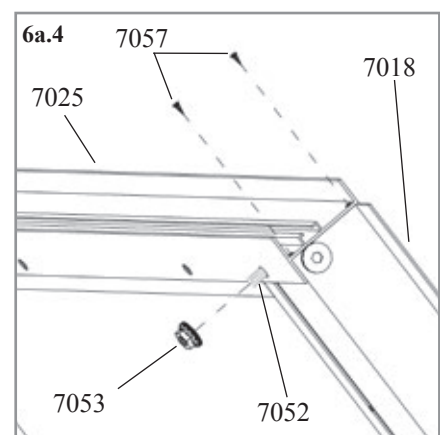
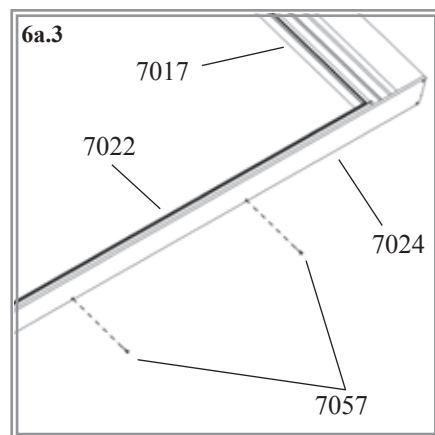
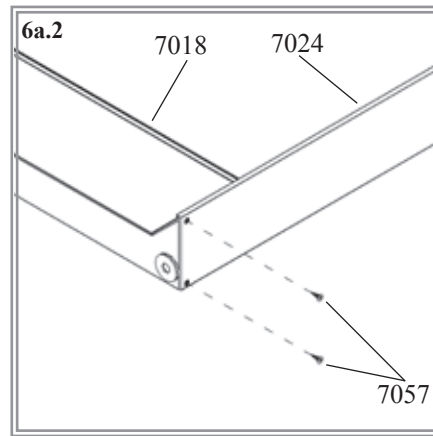
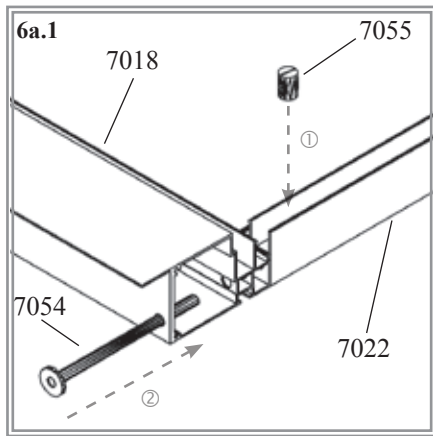
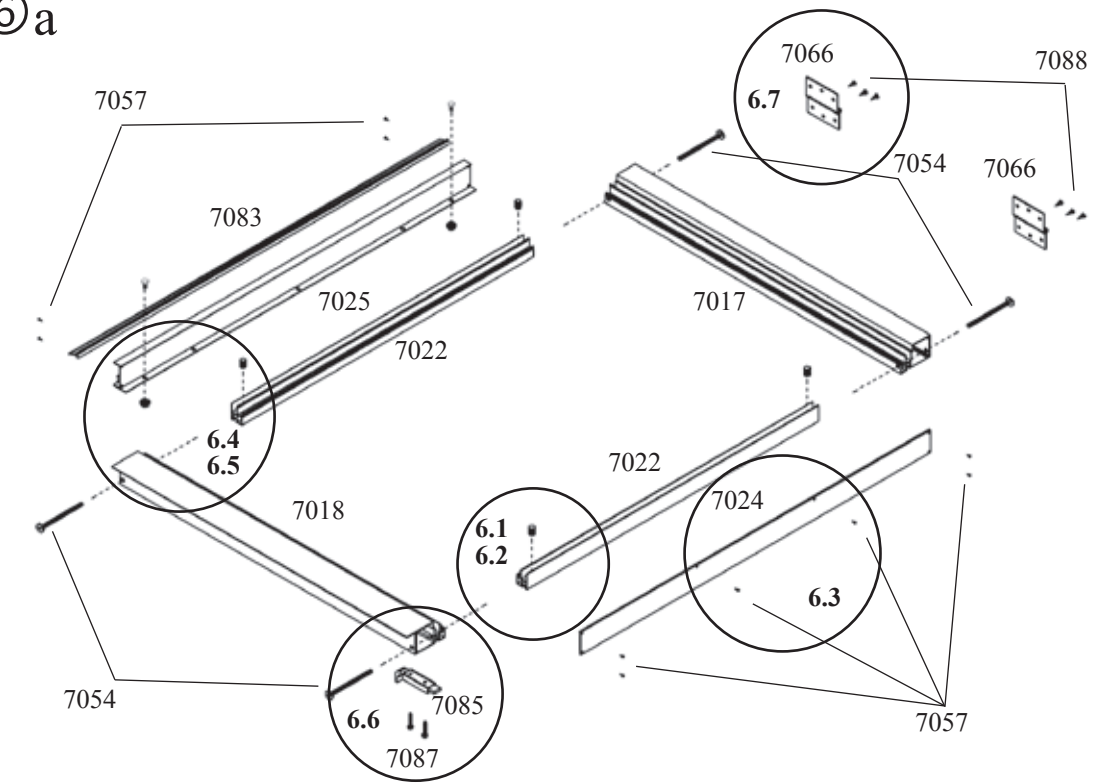

ZEUS

## ØVERSTE DØRDEL

### BEMÆRK VENLIGST:

Isætning af glas i dørene foretages på et senere tidspunkt.

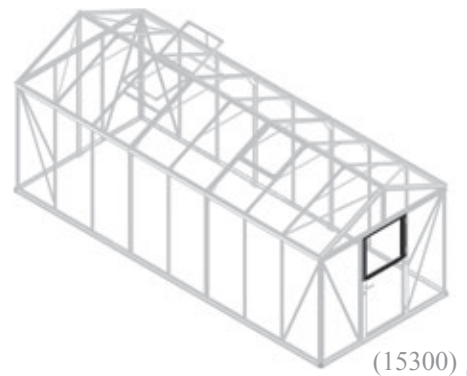

Sæt en tombolt 7052 med møtrik 7053 i profil 7017 og profil 7018.

Saml rammen til den øverste del af døren, der består af kode 7017, 7018 og 2 stk. 7022, ved hjælp af samleskrue 7054 og tværbøsning 7055 (6a.1).

Monter afdækningsprofil 7024 forneden (6a.2) og 7025 foroven med skrue 7057 og de tidligere monterede bolte 7052 og møtrikker 7053 (6a.4). Tætningsliste 7083 føres ind i den øvre afdækningsprofil 7025 (6a.5). Monter skudrigelen 7085 på den lodrette dørprofil 7018 (6a.5) ved hjælp af skruer 7087. Pladehængsel 7066 monteres på den lodrette dørprofil 7017 (6a.7) ved hjælp af skruer 7088.

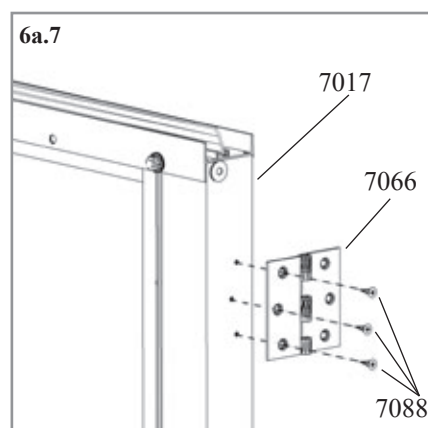
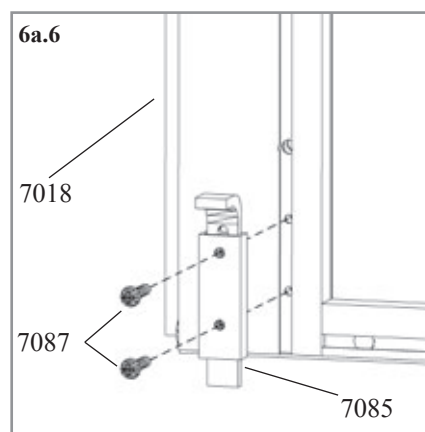
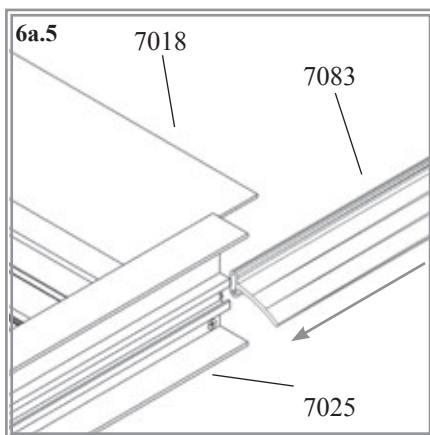

# 6b

ⓐ

Model	
13500	15300
7015	
1	1
7022	
2	2
7023	
1	1
7025	
1	1
7052	
4	4
7053	
4	4
7054	
4	4
7055	
4	4
7057	
8	8
7066	
2	2
7083	
1	1
7086	
1	1
7088	
12	12
7100 - 7108	
7216	
1	1

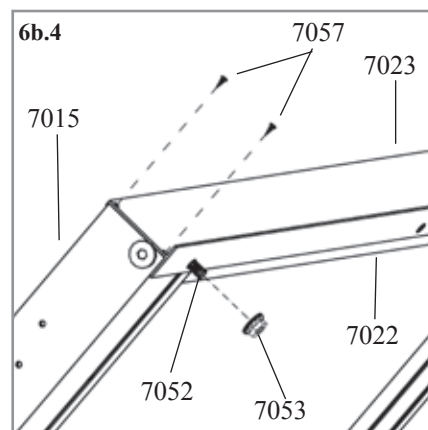
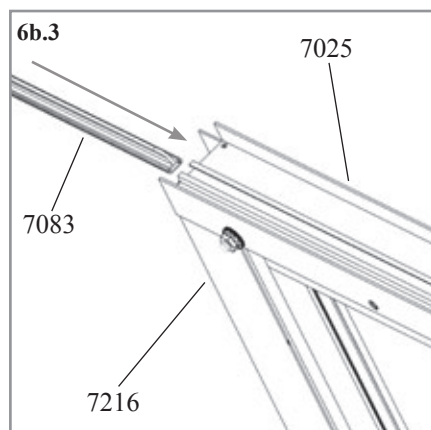
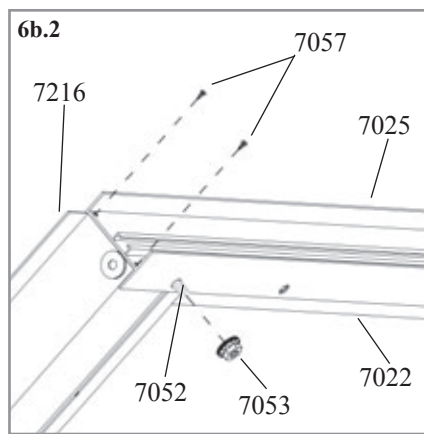
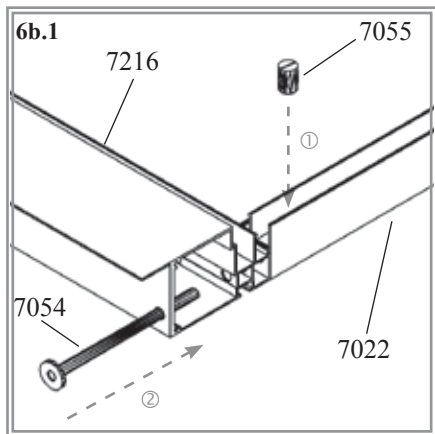
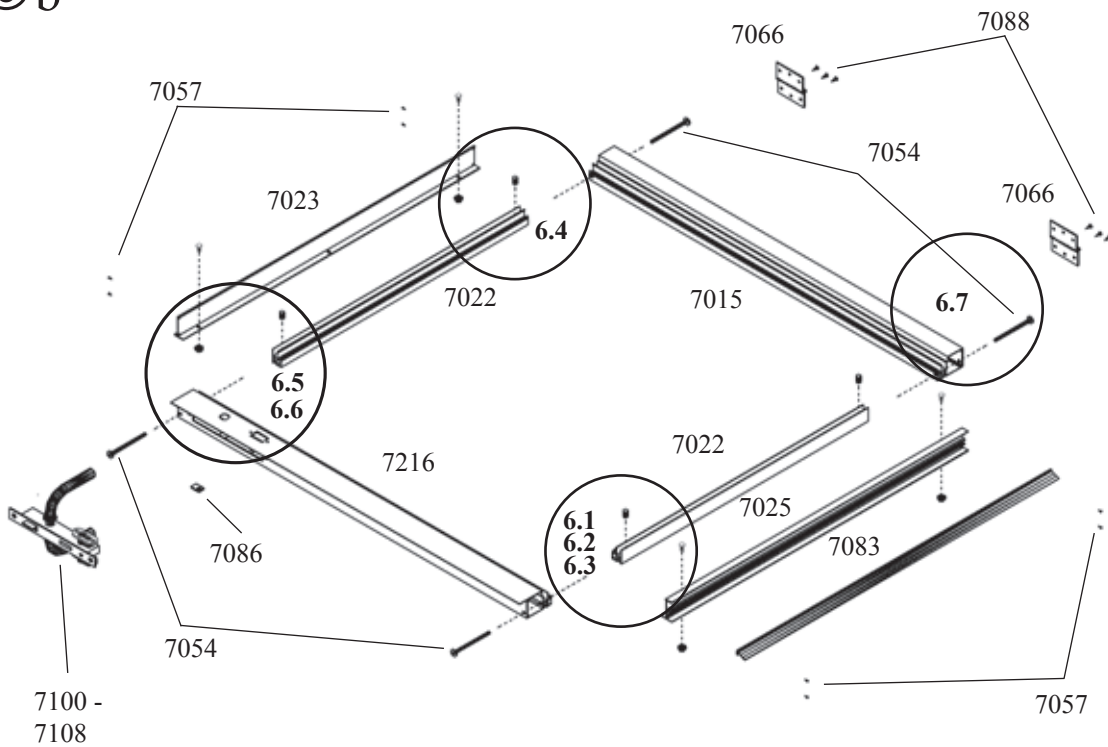

ZEUS

## NEDERSTE DØRDEL

### BEMÆRK VENLIGST:

Isætning af glas i dørene foretages på et senere tidspunkt.

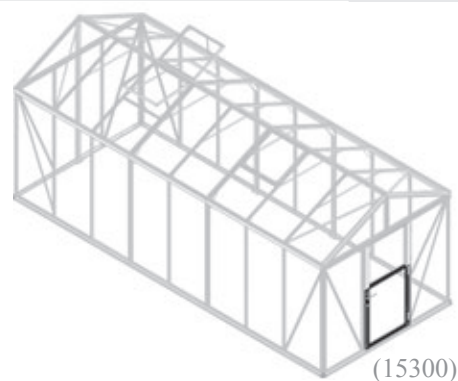

Monter to tombolte 7052 med møtrikker 7053 i hver af profilerne 7017 og 7018. Saml rammen til den nederste del af døren, der består af 7015, 7216 og 2 stk. 7022, ved hjælp af samleskrue 7054 og tværbøsning 7055 (6b.1).

Monter profil 7025 forneden (6b.3) og 7023 foroven med skrue 7057 og de tidligere monterede bolte 7052 og møtrikker 7053 (6b.4). Tætningsliste 7083 føres ind i den nederste afdækningsprofil 7025 (6b.3).

Løsn møtrik 7053 ovenover dørlåsen og fastgør dørrigelmellemstykke 7086 med møtrikken på dette sted (6b.5). Husk at anbringe den skrå flade opad som vist.

Monter låsen, der består af delene 7110 – 7106, se (6b.7).

Ved hjælp af skruer 7088 fastspændes hængslerne 7066 til den lodrette dørprofil 7015 (6b.7).

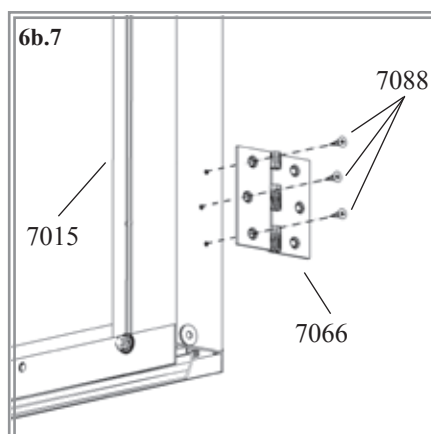
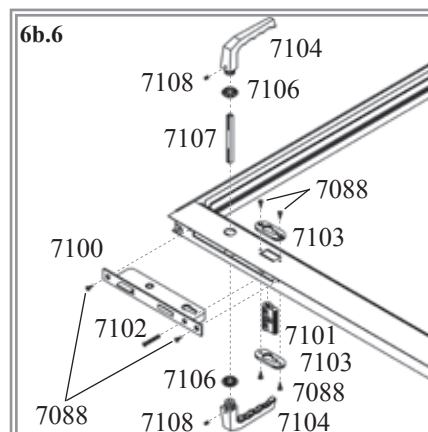
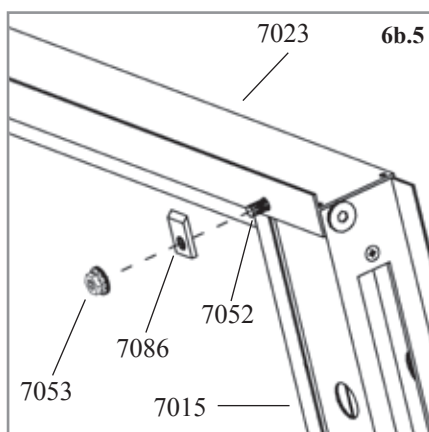

Nederste dørdeel

ZEUS

Model		
13500	15300	
6090 		
1	1	
A		
18	20	
B		
11	13	
C		
3	3	
E		
1	1	
F		
1	1	
G		
2	2	
H		
2	2	
J		
2	2	

Baggavl, alle modeller

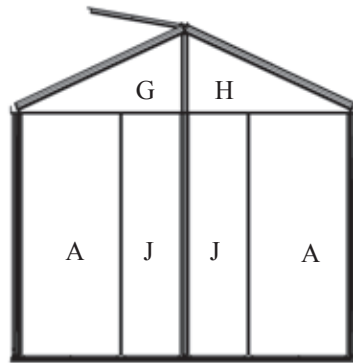

(13500)

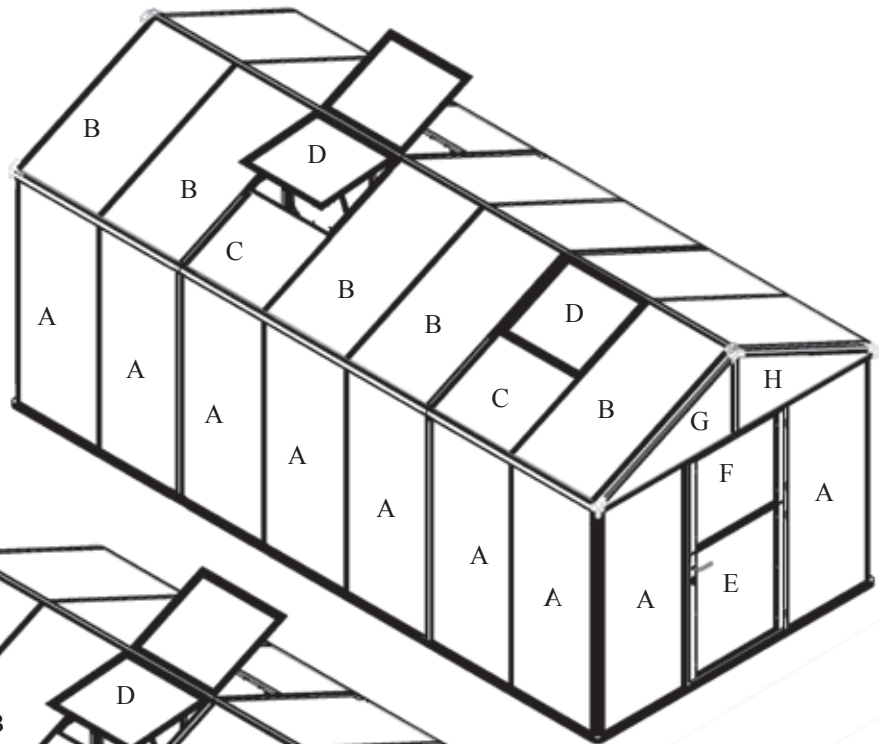

(15300)

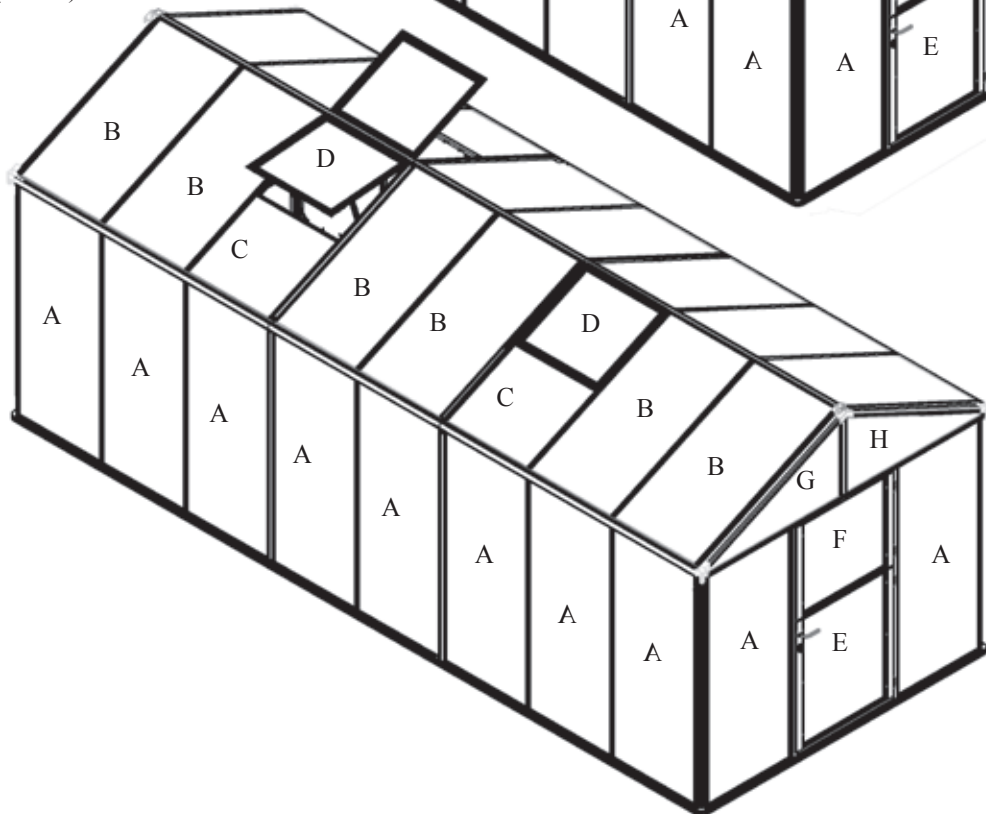



# GLASPLAN

## BEMÆRK VENLIGST:

Til dette trin i opbygningsprocessen bør der være 2 personer.  
Ved isætning af glas og polycarbonat bør der anvendes arbejds-  
handsker!

Bemærk den foreskrevne rækkefølge til isætning af glas.

Den udvendige side af polycarbonatpladerne er forsynet med en  
plastfolie eller mærket på anden vis.

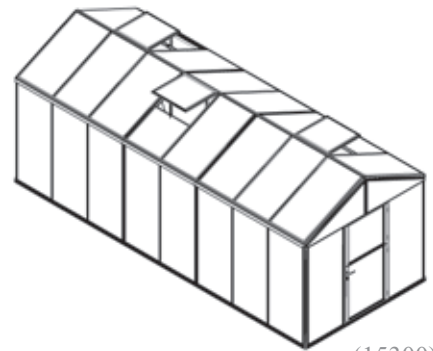

(15300)

Start med at sortere glas og polycarbonatplader efter modeltype i henhold til oversigten  
i tabel (7.1).



Den UV-beskyttede side af polycarbonatpladerne er påsat en tynd plastic-  
folie eller der er trykt en tekst ved pladekanterne. Denne side SKAL vende  
udad. Fjern først folien, når pladerne er monteret, da der ellers ikke er synlig  
forskel på den udvendige og indvendige side af pladerne.

# Glasplan

7.1	Kode nr. - Glasplan							
	POLYCARBONATPLADER						GLAS	
	6 MM		10 MM		16 MM		4 MM	
<b>A</b>	3695711	725 x 1790	3695712	725 x 1790	3695713	725 x 1790	367801	725 x 1790
<b>B</b>	3695724	725 x 1359	3695724	725 x 1359	3695725	710 x 1355	3695724	725 x 1359
<b>C</b>	3695734	725 x 693	3695734	725 x 693	3695735	710 x 677	3695734	725 x 693
<b>D</b>	3695744	670 x 660	3695744	670 x 660	3695745	645 x 637	3695744	670 x 660
<b>E</b>	3695751	725 x 966	3695752	725 x 966	3695753	725 x 966	367805	725 x 966
<b>F</b>	3695761	725 x 683	3695762	725 x 683	3695763	725 x 683	367806	725 x 683
<b>G</b>	3695771	1190x567/15	3695772	1190x567/15	3695773	1190x567/15	367807	1190x567/15
<b>H</b>	3695781	1190x567/15	3695782	1190x567/15	3695783	1190x567/15	367808	1190x567/15
<b>J</b>	3695791	435 x 1790	3695792	435 x 1790	3695793	435 x 1790	367809	435 x 1790

ZEUS

# 7a

(15300)

7a.1	KODE 2-KODE 1-KODE 2	LÆNGDE
13500	7210-7211-7210	1520 + 2264 + 1520 mm
15300	7211-7210-7211	2264 + 1520 + 2264 mm

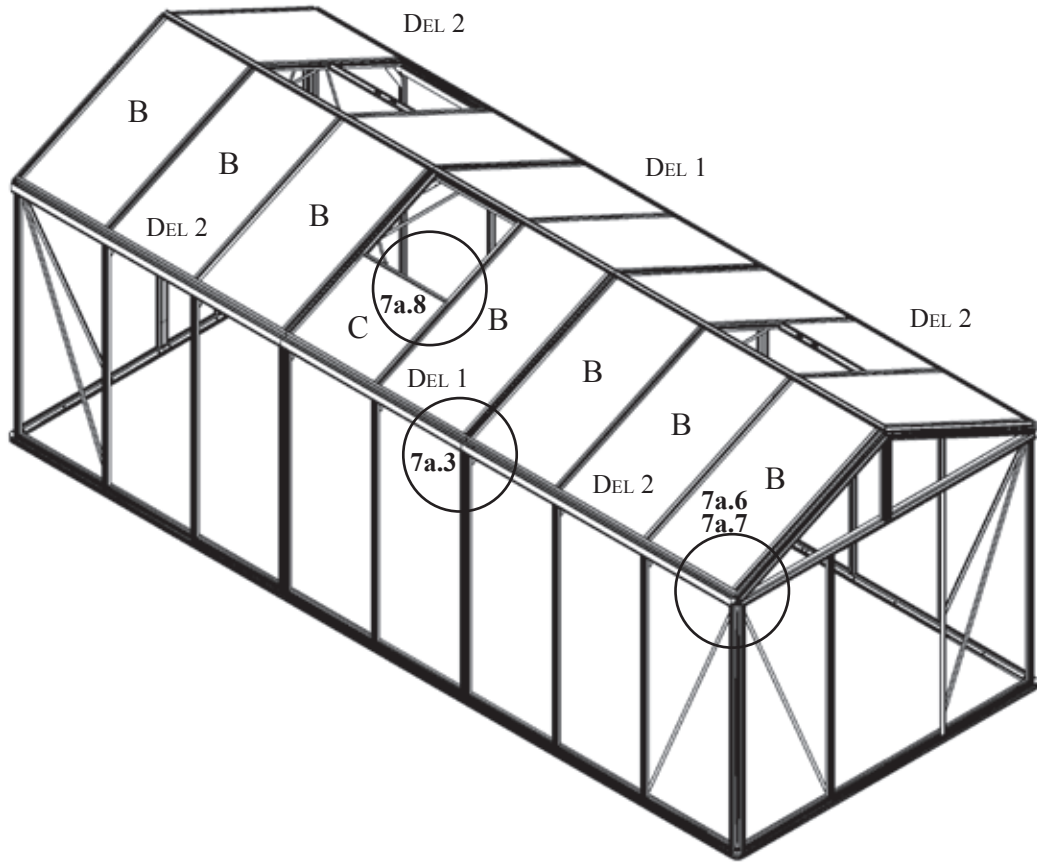

Model	
13500	15300
7052	
18	18
7053	
18	18
7061	
4	4
7064	
4	4
7080	
16	16
7207	
4	4
7210	
4	2
7211	
2	4
<b>B</b>	
11	13
<b>C</b>	
3	3

7a.2	Kode nr. - Glasplan			
	POLYCARBONATPLADER			
	10 MM		16 MM	
<b>B</b>	3695724	725 x 1359	3695725	710 x 1355
<b>C</b>	3695734	725 x 693	3695735	710 x 677

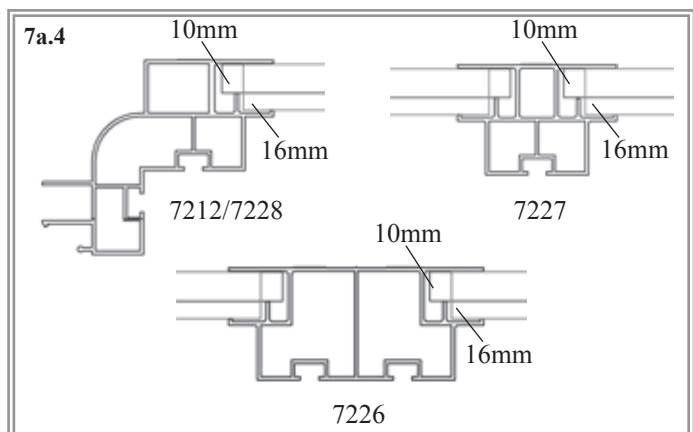
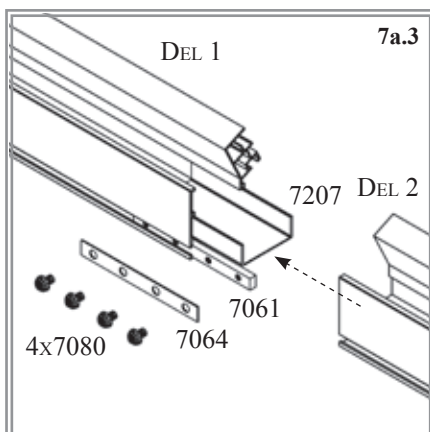

ZEUS



## ISÆTNING AF GLAS I TAGET / TAGRENDE (TAGREM)

### BEMÆRK VENLIGST:

Til dette trin i opbygningsprocessen bør der være 2 personer – og meget gerne 3.

Ved isætning af glas og polycarbonat bør der anvendes arbejds-handsker!

Bemærk den foreskrevne rækkefølge til isætning af glas.

Den udvendige side af polycarbonatpladerne er forsynet med en plastfolie eller mærket på anden vis.

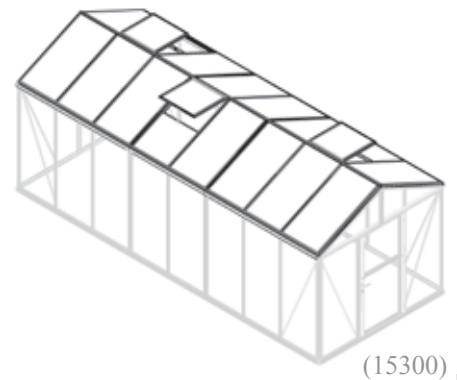

Klargør tagrenderne til slutmontage ved at forbinde tagrendeprofilerne i henhold til tabel (7a.1) med samlebeslagene 7207, 7061 og 7064 og bolte 7080 (7a.3). Indsæt 9 (ni) tombolte uden møtrikker i hver tagrendeprofil. Læg tagrendeprofilerne midlertidigt til side.

Ilæg polycarbonatpladerne i taget i henhold til tabel (7a.2) og ill. (7a.4 – 7a.5).



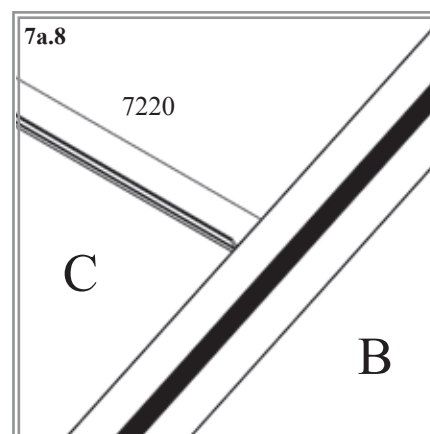
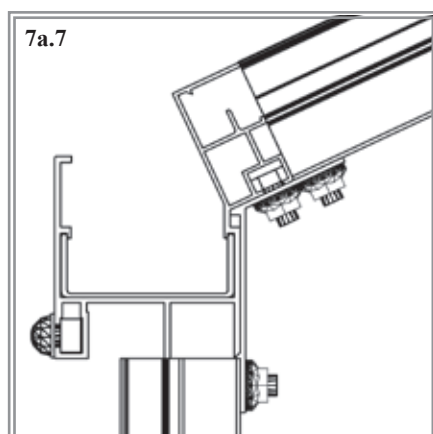
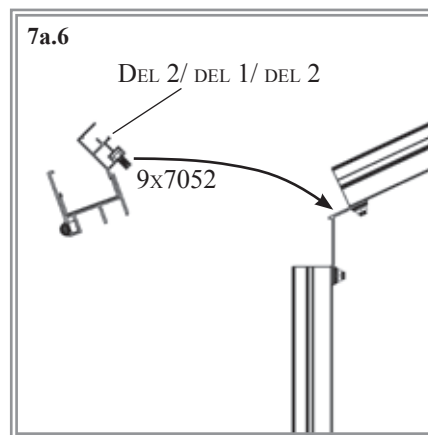
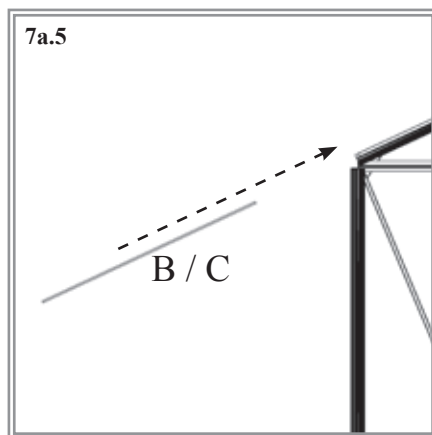









Monter den i afsnit 2 klargjorte tagrendeprofil på tagremprofil 7208/7209 (7a.6 – 7a.7).



Isætning af glas i taget / tagrende (tagrem)

ZEUS

# 7b

Model	
13500	15300
6090	
1	1
7030	
2	2
7032	
10	12
7033	
18	18
7034	
18	20
7036	
1	1
7044	
2	2
7050	
172	184
7053	
172	184
7074	
2	2
7075	
2	2
7076	
2	2
7077	
2	2
A	
18	20
G	
2	2
H	
2	2
J	
2	2
<b>ZEUS</b>	

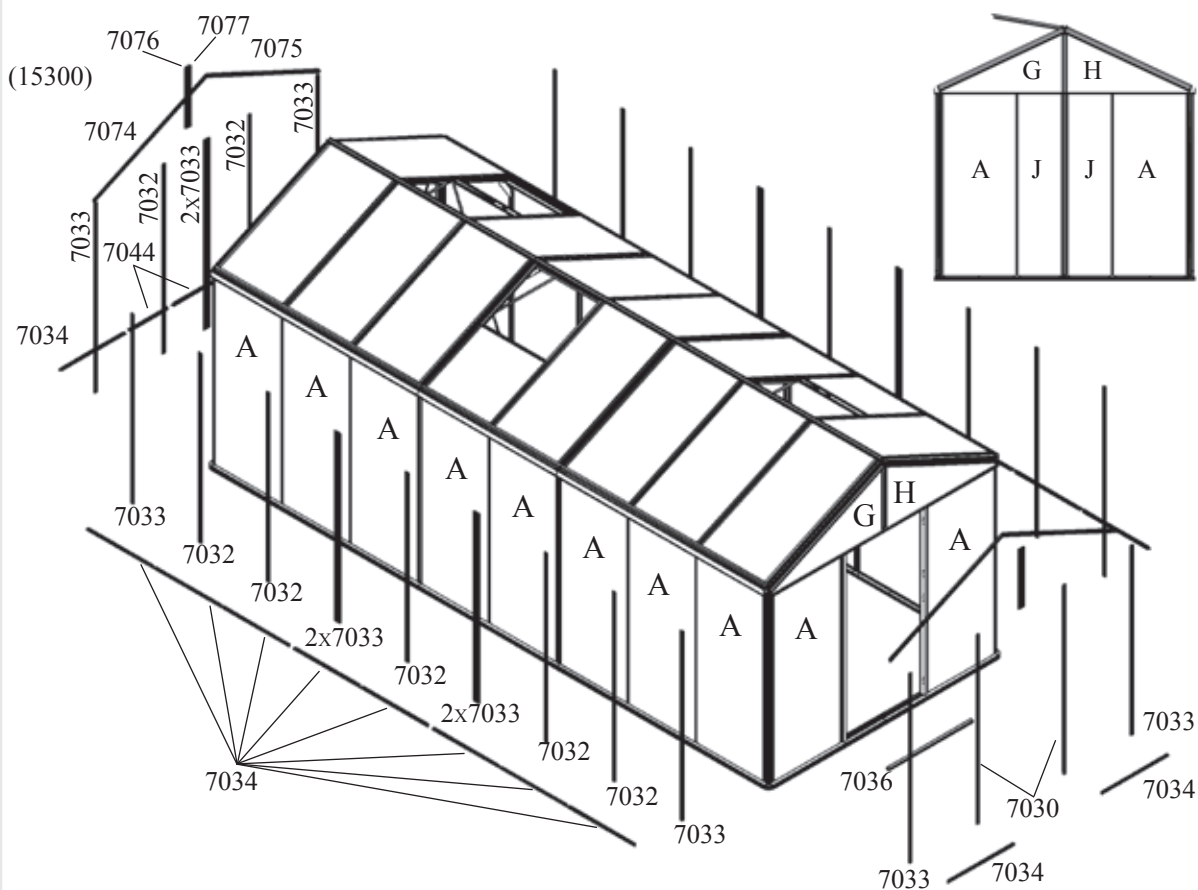

7b.1	Kode nr. - Glasplan							
	POLYCARBONATPLADER						GLAS	
	6 MM		10 MM		16 MM		4 MM	
<b>A</b>	3695711	725 x 1790	3695712	725 x 1790	3695713	725 x 1790	367801	725 x 1790
<b>G</b>	3695771	1190x567/15	3695772	1190x567/15	3695773	1190x567/15	367807	1190x567/15
<b>H</b>	3695781	1190x567/15	3695782	1190x567/15	3695783	1190x567/15	367808	1190x567/15
<b>J</b>	3695791	435 x 1790	3695792	435 x 1790	3695793	435 x 1790	367809	435 x 1790

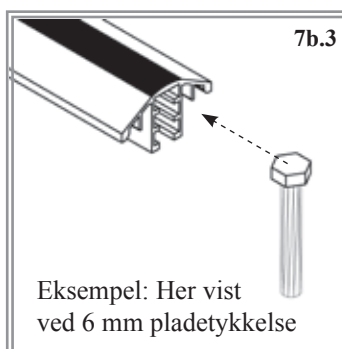
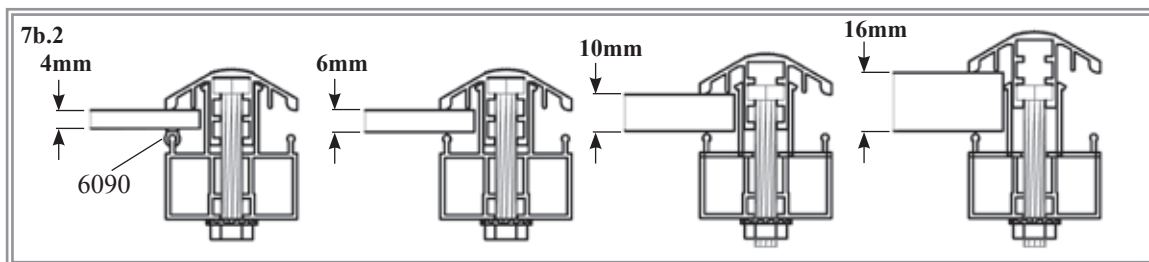

## ISÆTNING AF GLAS I SIDERNE

### BEMÆRK VENLIGST:

Til dette trin i opbygningsprocessen bør der være 2 personer – og meget gerne 3.

Ved isætning af glas og polycarbonat bør der anvendes arbejds-handsker!

Bemærk den foreskrevne rækkefølge til isætning af glas.

Den udvendige side af polycarbonatpladerne er forsynet med en plastfolie eller mærket på anden vis.

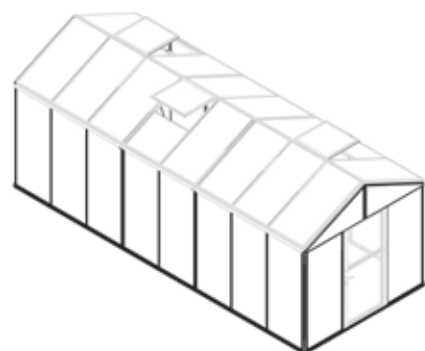

(15300)

Fastgørelseslisterne/dæklisterne kan anvendes til forskellige glas/pladetykkelser. For at muliggøre dette, skal bolte 7058 indføres i forskellige positioner i afdækningslisterne (7b.2). Klargør afdækningslisterne med tre bolte 7058 hver, som vist på ill. (7b.3). Anbring glas/polycarbonatplader i henhold til tabel (7b.1) på de klargjorte profiler i de viste positioner uden at spænde møtrikkerne 7053 til endnu.

Klargør på samme måde de vandrette dæklister 7034 med hver tre bolte. Glasset skal løftes lidt for at muliggøre montering af profilerne.

Når møtrikkerne spændes, skal De være påpasselig med ikke at spænde dem for hårdt.

Ved isætning af 4 mm glas i hele baner skal glasliste 6090 først monteres på profilerne som vist i (7b.2 detalje 1).

Ved isætning af polycarbonatplader anvendes glaslisten ikke.

Isætning af glas i siderne

# 7c

Model		
13500	15300	
6090		
1	1	
7031		
2	2	
7034		
4	4	
7035		
2	2	
7053		
22	22	
7058		
22	22	
<b>E</b>		
1	1	
<b>F</b>		
1	1	

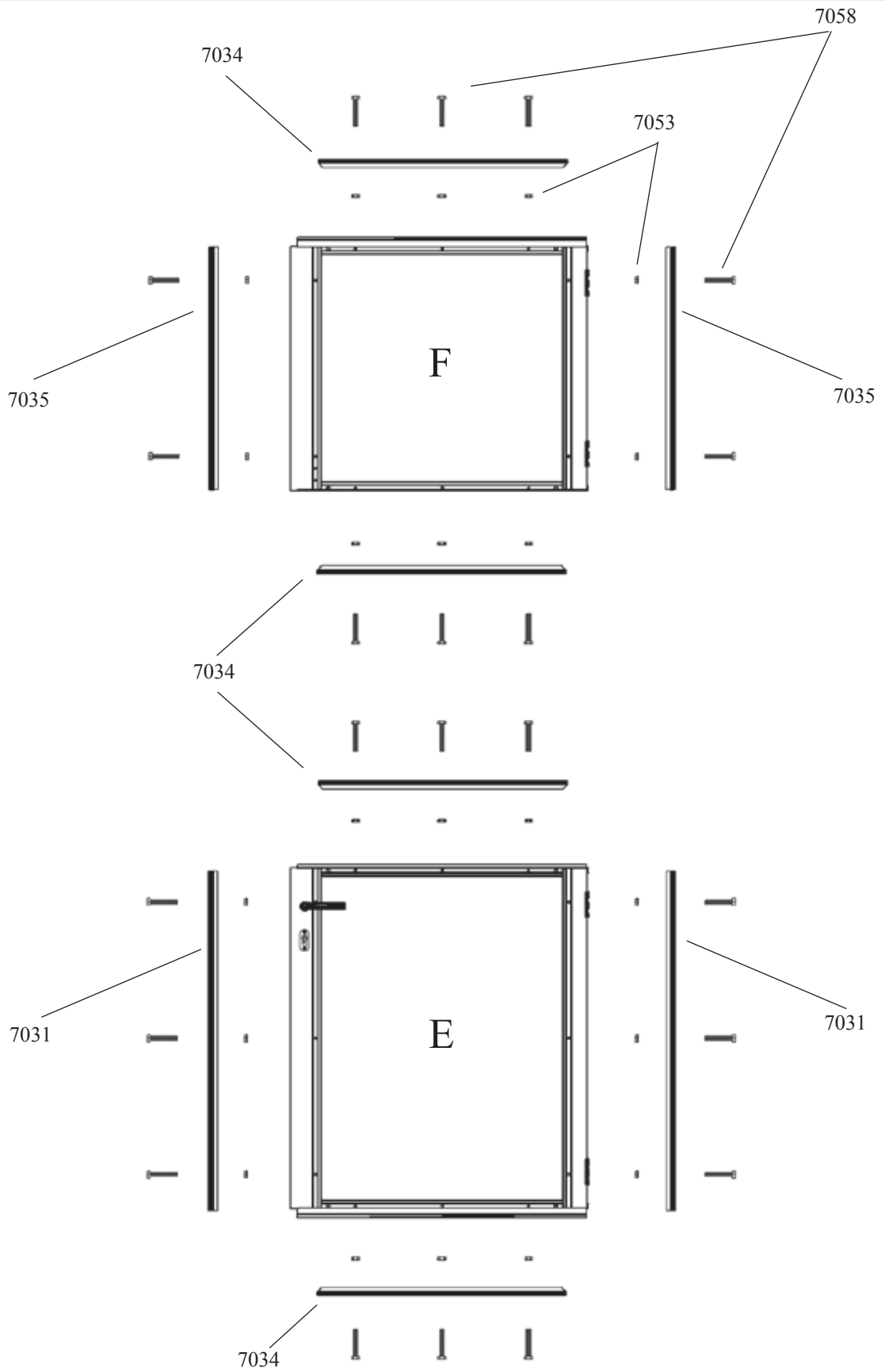

7c.1	Kode nr. - Glasplan							
	POLYCARBONATPLADER						GLAS	
	6 MM		10 MM		16 MM		4 MM	
<b>E</b>	3695751	725 x 966	3695752	725 x 966	3695753	725 x 966	367805	725 x 966
<b>F</b>	3695761	725 x 683	3695762	725 x 683	3695763	725 x 683	367806	725 x 683

**ZEUS**

## ISÆTNING AF GLAS I DØR

### BEMÆRK VENLIGST:

Ved isætning af glas og polycarbonat bør der anvendes arbejds-  
handsker!

Bemærk den foreskrevne rækkefølge til isætning af glas.

Den udvendige side af polycarbonatpladerne er forsynet med en  
plastfolie eller mærket på anden vis.

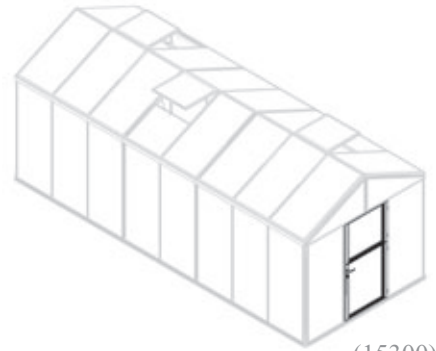

(15300)







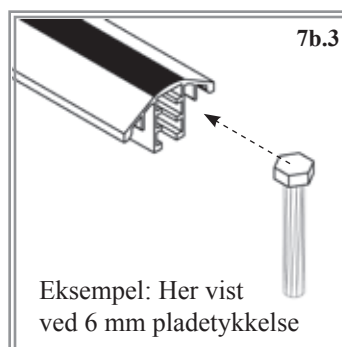
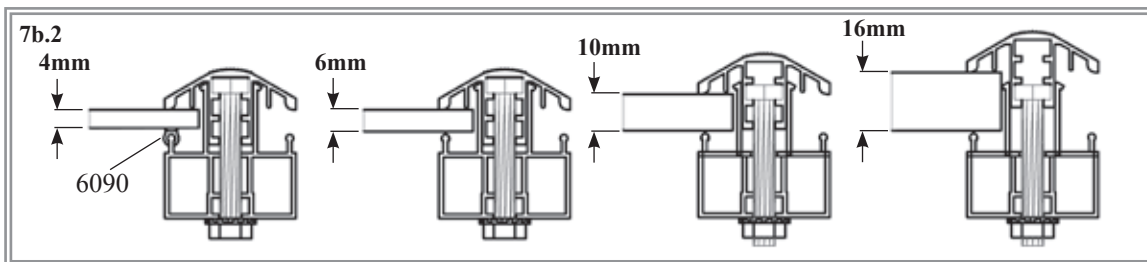

Fastgørelseslisterne/dæklisterne kan anvendes til forskellige glas/pladetykkelser. For at muliggøre dette, skal bolte 7058 indføres i forskellige positioner i afdækningslisterne (7b.2). Klargør afdækningslisterne med bolte 7058 som vist på ill. (7b.3). Som vist på den store ill. side 52, skal der tre bolte 7058 i profil 7031 og 7034, men kun 2 bolte 7058 i profil 7035. Anbring glas/polycarbonatplader i henhold til tabel (7c.1) på de klargjorte profiler i de viste positioner uden at spænde møtrikkerne 7053 til endnu.

Når møtrikkerne spændes, skal De være påpasselig med ikke at spænde dem for hårdt.

Ved isætning af 4 mm glas i hele baner skal glasliste 6090 først monteres på profilerne som vist i (7b.2 detalje 1).

Ved isætning af polycarbonatplader anvendes glaslisten ikke.



Model		
13500	15300	
7056		
4	4	
7088		
12	12	
7110		
1	1	
7111		
1	1	
7112		
2	2	
7267		
2	2	
7270		
2	2	
7271		
2	2	

(15300)

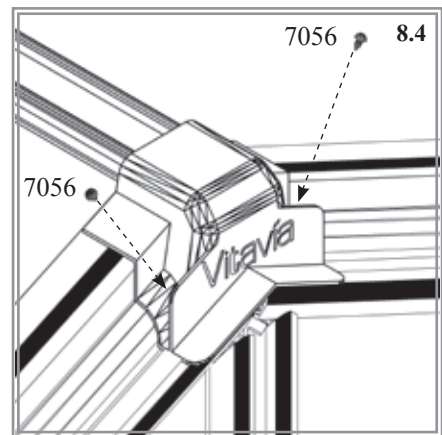
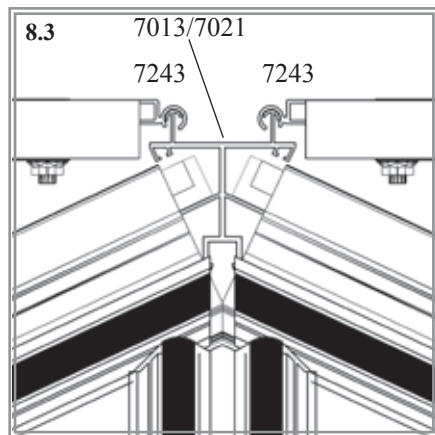
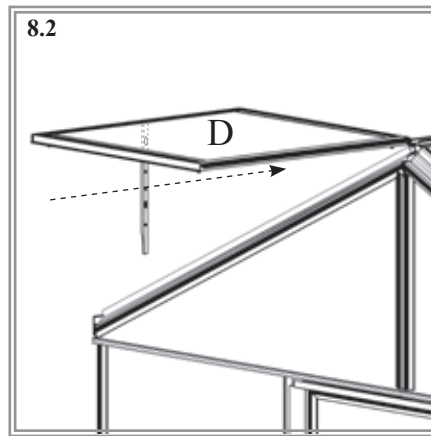
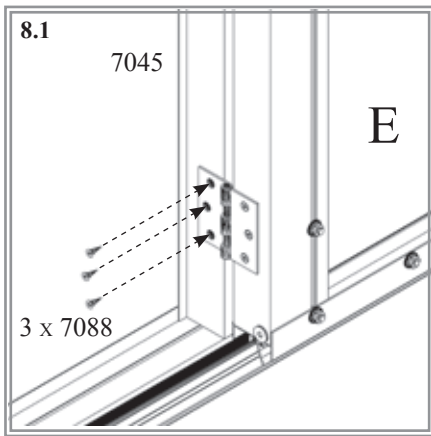
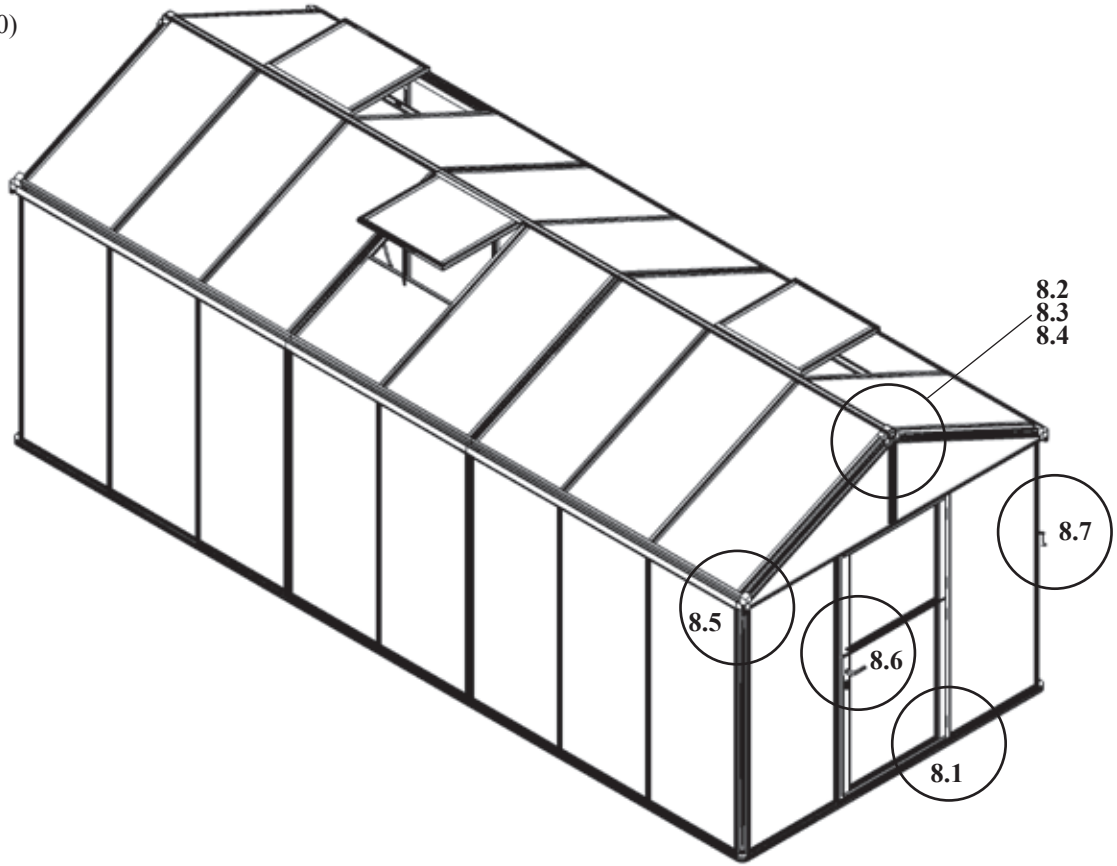

## FÆRDIGGØRELSE

### BEMÆRK VENLIGST:

**Kontroller, at alle bolte og møtrikker er monteret korrekt, og at de har anslag og er spændte. Efter ca. 14 dage kontrolleres, om møtrikkerne har fast hold, ellers efterspændes uden at overspænde.**

Fastgør både den øverste og den nederste dørdel (6a og 6b) til dørrammen 7045 (8.1) ved hjælp af de selvskærende skruer 7088.

Skub ventilationsvinduerne på plads ved at lade disse glide ind i sporet på tagryggen.

Pres afløbsstudserne 7271 og 7270 på plads ind i tagrenderne 7210/7211 (8.5).

Monter tagrygafdækningen 7267 med selvskærende skruer 7056.

Monter øsken 7111 på dørprofil 7018 i det forborede hul som vist i 8.6. Husk at montere afstandsbøsning 7112.

Monter dørkrog 7110 og afstandsbøsning 7112 i hjørnestolpen 7007 i det forborede hul.

Den vedlagte selvklæbende identifikationsetiket anbringes indvendigt i drivhuset – f.eks. indvendig på døren eller lign. Oplysningerne på etiketten vil gøre det meget lettere for Dem at fremskaffe reservedele, såfremt dette skulle blive aktuelt.

Vi ønsker Dem god arbejdslyst og håber, at De får rigtig mange gode stunder med og i Deres Vitavia drivhus.

Med venlig hilsen

OPJ A/S

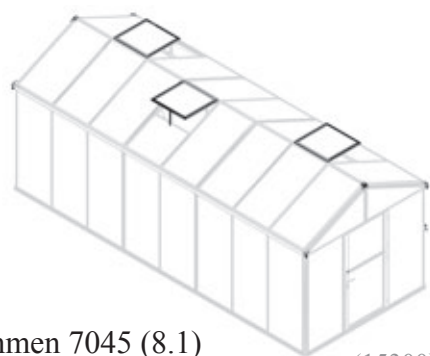

(15300)

Færdiggørelse

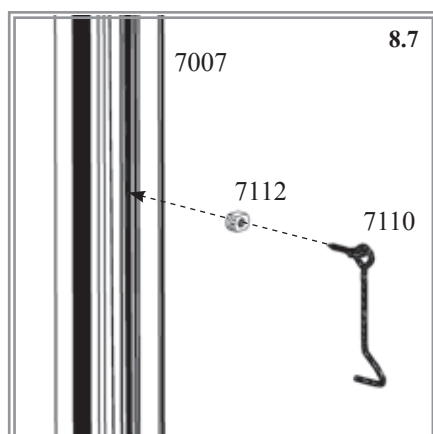
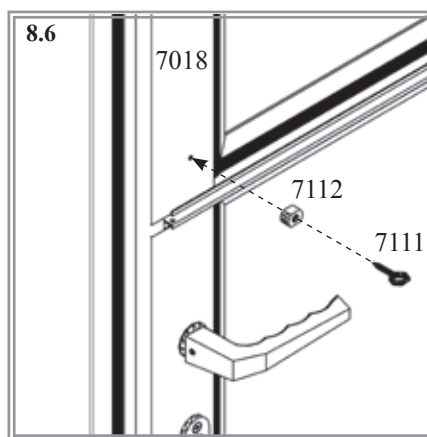
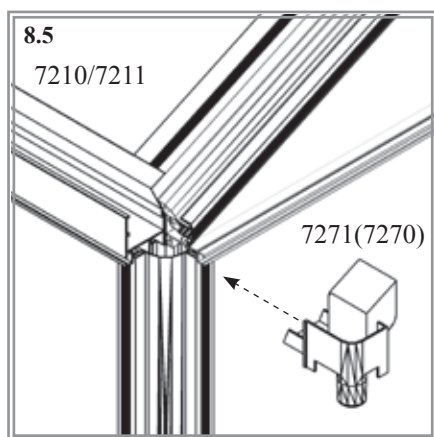

ZEUS



E.P.H. Schmidt u. Co. GmbH  
Hoeferstrasse 30  
44149 Dortmund  
Postfach 170163  
44060 Dortmund  
Deutschland  
Tel.: +49 231 941655 0  
Fax: +49 231 941655 99  
[www.eph-schmidt.de](http://www.eph-schmidt.de)  
[verkauf@eph-schmidt.de](mailto:verkauf@eph-schmidt.de)

OPJ A/S  
Volderslevej 36 A  
5260 Odense S  
Danmark  
Tel.: +45 66 15 10 30  
Fax: +45 66 15 00 84  
[www.opj.dk](http://www.opj.dk)  
[opj@opj.dk](mailto:opj@opj.dk)